



libbi
zappi
eddi
harvi
hub



myenergi eco-system

INSTALLER

Commissioning Guidance

in accordance with EREC G100 Issue 2

REVISION B



Contents

1.	Overview	3
2.	The myenergi CLS	3
3.	How it works	3
4.	Compliant Products	4
5.	Device Behaviour with Respect to Current	5
6.	Typical Installation Diagrams	6
7.	Where to Find the Device Manuals	7
8.	Commissioning.....	7
8.1	Commissioning Tests and DNO Witness Tests	7
8.2	Fail Safe Tests	7
8.3	Fault Messages and Counters	7
8.4	Clear State 2 and 3 Counters	8
9.	User Reset	8
10.	Manufacturer's Lockout.....	8
11.	Help Centre.....	8
	Appendix A	9



1. Overview

As customers are becoming increasingly aware of environmental issues and are seeking to install low carbon technology devices, such as heat pumps, electric vehicle charging points and photovoltaic generation within their premises that might add significant load and/or generation (including electricity storage) on to Distribution Networks. Where the Distribution Network Operator (DNO) has assessed that connection of such devices will require costly reinforcement, or reinforcement that would take time to implement thus delaying the connection, some customers may choose to restrict the net flows of electricity at their connection point rather than wait for, or contribute to, the reinforcement.

A typical Customer Limitation Scheme (CLS) may be used in the following scenarios:

- Installing generation with an aggregate current rating greater than the permitted export to the network and limiting the peak export;
- Connecting significant new loads which cannot operate at their full capacities at the same time without exceeding the import capacity from the network;
- Using the flexibility of the customer's loads and generation to stay within import or export limits.

For installations within England, Scotland and Wales, Implementation of Engineering Recommendation G100 issue 2¹ became mandatory for systems commissioned from 1st May 2023.

2. The myenergi CLS

The myenergi eco system CLS is registered on the ENA Type Test Register under MYENE/09150/V1, link to ENA TTR <https://www.ena-eng.org/gen-ttr/index?Action=Home>. The following products installed in-accordance with this guide document and G100 Issue 2 installation methods, provide the functionality and safeguards to protect the DNO supply.

- libbi
- zappi
- eddi
- harvi
- hub

For compliant models and firmware version, refer to section 4.

3. How it works

Once the CLS is setup correctly, the master device within the myenergi eco-system will monitor the maximum import and export and if necessary, instruct other devices to increase or decrease import or export if these maximum thresholds are ever exceeded. All devices pass secure status messages to other myenergi connected devices.

According to G100 Issue 2 there are four operating states:

State 1 – This is normal operation, and all devices will normally operate under this state.

State 2 – When the maximum import or export threshold is exceeded, or if the communications between devices is lost, then one or more devices enter state 2. If state 2 persists for more than 10 seconds, then the CLS records an excursion. A well designed and commissioned system should never enter this state.

State 3 – This state stops normal functionality and devices will reduce their active power imported/exported to zero. In the following situations, the CLS will enter state 3.

- If the CLS exceeds the MIL or MEL thresholds for greater than 60 seconds,
- If the CLS exceeds the MIL or MEL thresholds for more than 15 seconds but less than 60 seconds, three times in a 24 hour period,
- The time between any two 15 seconds or more, consecutive breaches of the MIL or MEL, within a 10-minute window.
- If the measured grid current exceeds the state 3 thresholds.

Lockout – If the CLS has entered state 3 more than three times, then the CLS is locked out and normal operation of the devices is not permitted. Unfortunately, lockout of a CLS usually means there is either a fault present within a system or that the CLS has not been setup correctly. Unlocking of the CLS can only take place by the installer or myenergi Technical Support.

¹Energy Networks Association Engineering Recommendation G100 Issue 2 2002 Amendment 1 Technical Requirements for Customers' Export and Import Limitation Schemes.



The installer is responsible for the installation and proper commissioning of each installation; therefore, they must ensure that house import and export has been accurately calculated. Failure to do so will result in improper operation of the CLS.

The following block diagram represents a typical myenergi CLS.

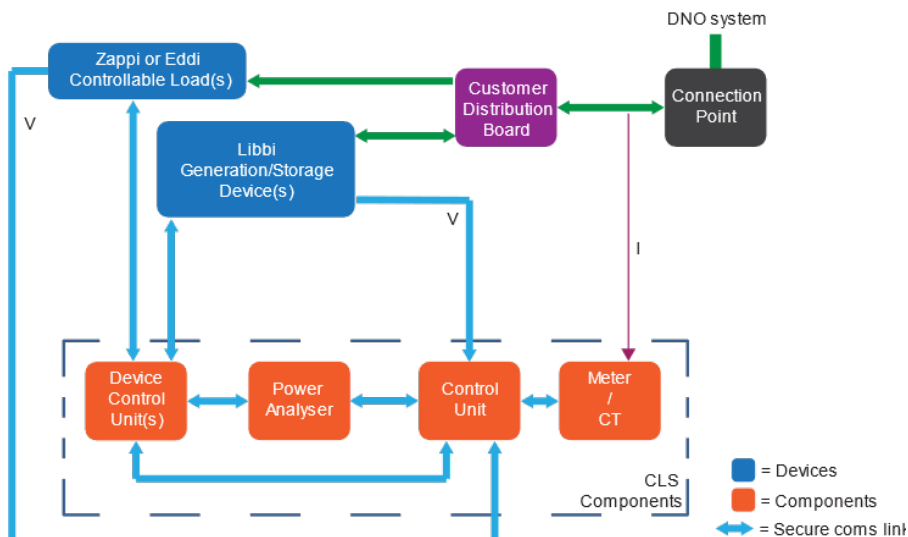

myenergi products incorporate robust functions to measure, analyse, control, and monitor a customer’s installation under G100/2, through the master device. Except for when using the harvi, the hardwired CT must be connected to the master device under a CLS.

All intra-device communications are either via hardwired Ethernet, WiFi and/or local radio comms.

4. Compliant products

The following models, only, are compliant with G100 issue 2. The G100 master device of a CLS must be the device with the grid CT connected or, where a harvi is used for the grid CT, the device that is paired directly with the harvi.

Model	Model code	G100 master	Firmware version
libbi	LIBBI-C110W	Y	V5.400 onward
zappi	ZAPPI-207** ²	N	V5.4.00 onward
	ZAPPI-222** ²		
	ZAPPI-2H****	Y	V5.400 onward
eddi	EDDI-16A1P01 ²	N	V5.400 onward
	EDDI-16A1P02H	Y	V5.400 onward
harvi ³	HARVI-65A3PR	-	N/A
	HARVI-65A3P	-	N/A
hub	hub-V2	-	N/A

Table 1 – Compliance models and firmware versions

For models that are not classed as a G100 master device, these must only be configured as a slave device for controlling its own load.

To activate G100 master device functionality, via the wizard, following an over the air firmware update, please factory reset the device from the menu by navigating to Advanced Menu [Installer Settings] > System > Restore Settings > Erase All > Confirm.

When the device restarts, you will be taken through the new set-up wizard which includes the configuration of G100 settings.

²This model can only be used as a slave device. It is not G100 compliant to make this the master device.

³harvi is limited to installations with 60A DNO fuses only. For 80/100A DNO fuses, harvi is not permitted.



5. Device Behaviour with Respect to Current

The following table details the operating states at different current thresholds for the G100 master product models and harvi, detailed in section 4.

	DNO Fuse	Reading	State
harvi	60A only	0.45A - 59.99A	1
		60.00A - 71.99A	2
		≥72A	3
zappi-2H####	60A	0A - 59.99A	1
		60A - 86.99A	2
		≥87A	3
	80A	0A - 79.99A	1
		80A - 115.99A	2
		≥116A	3
	100A	0A - 99.99A	1
		100A - 119.99A	2
		≥120A	3
libbi Controller	60A	0A - 59.99A	1
		60A - 86.99A	2
		≥87A	3
	80A	0A - 79.99A	1
		80A - 115.99A	2
		≥116A	3
	100A	0A - 99.99A	1
		100-119.99A	2
		≥120A	3
EDDI-16A1P02H	60A	0-59.99A	1
		60A - 86.99A	2
		≥87A	3
	80A	0-79.99A	1
		80 - 115.99A	2
		≥116A	3
	100A	0A - 99.99A	1
		100-119.99A	2
		≥120A	3



6. Typical Installation Diagrams

The following are two typical examples for a myenergi CLS set up.

60A Grid Supply

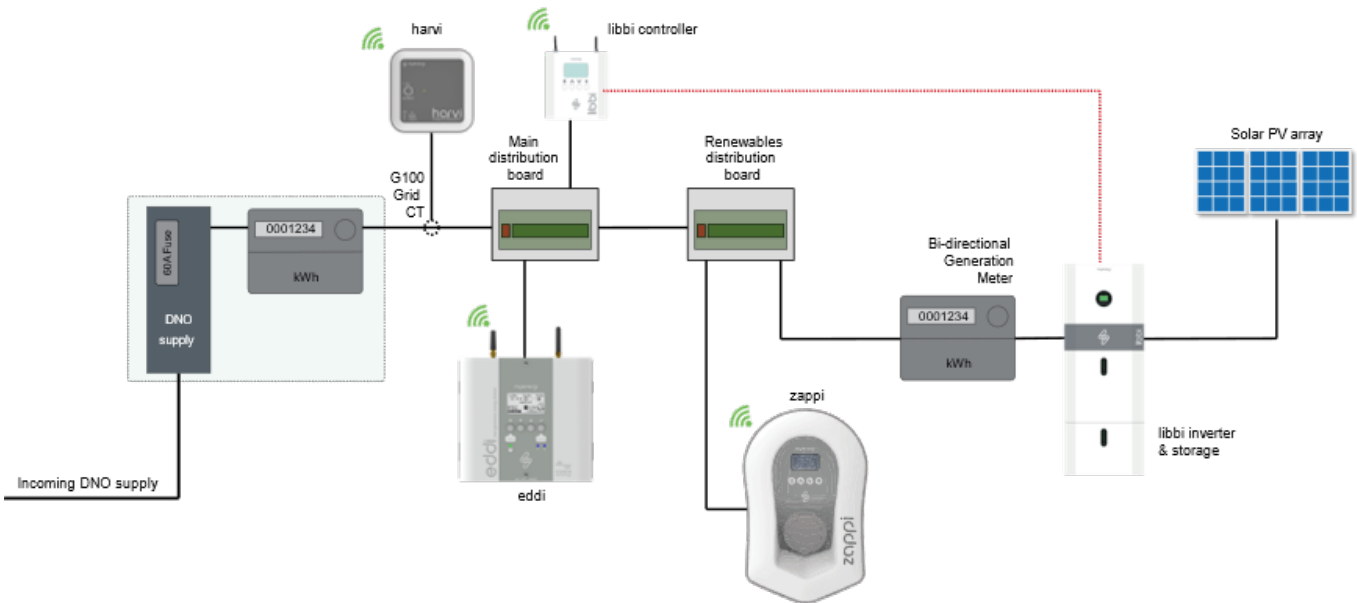

60/80/100A Grid Supply

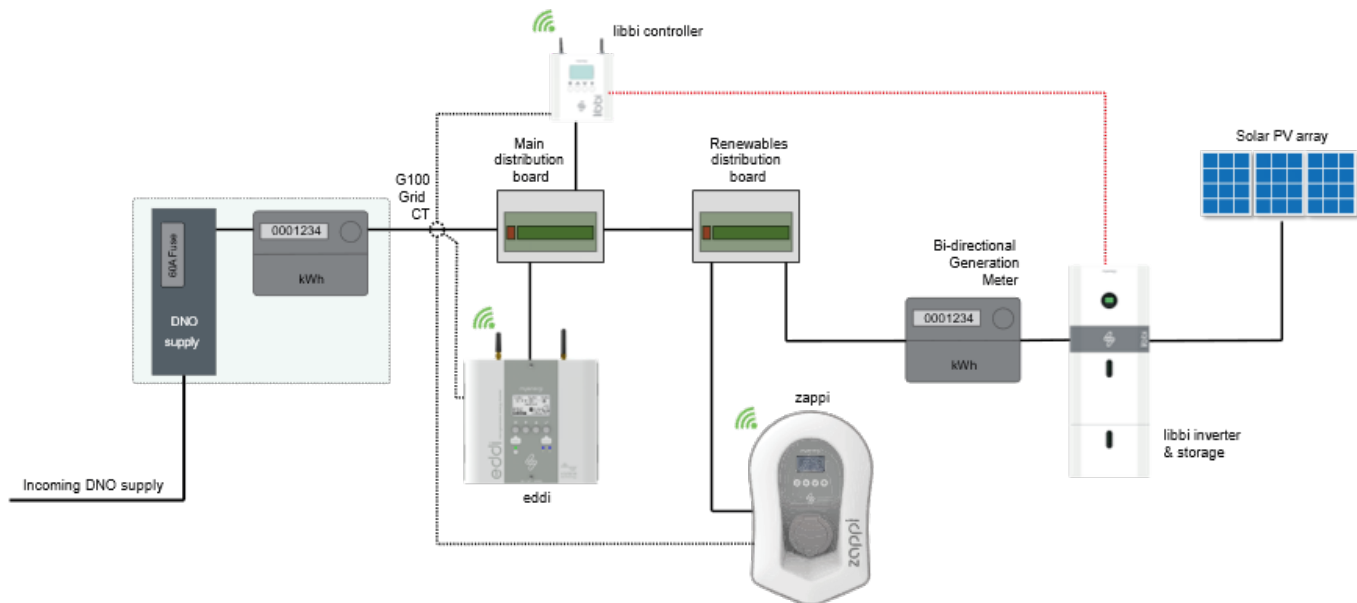

The dotted line in the example above indicates that the G100 grid CT can be wired to any one of the myenergi devices⁴.

⁴The libbi inverter is a component of the whole libbi BESS (battery energy storage system), the CT can only be connected to the libbi controller component of this libbi system.

7. Where to Find the Device Manuals.

Please refer to the relevant product manuals for further guidance clicking the link or by scanning the QR Code below.



<https://support.myenergi.com/hc/en-gb>

8. Commissioning

Before configuring the CLS, please ensure that the firmware versions on each device meet the minimum requirements, in accordance with table 1. To configure a CLS follow the setup wizards on each myenergi device, ensuring that;

1. The region is set to UK.
2. Confirm that G100/2 is required.
3. Set export limit to 16A, 22A, 32A, 60A or 100A (per phase values).
4. Set import limit to 60A, 80A or 100A (per phase values).
5. Follow prompts to set passcode for the installer settings menu.

In accordance with G100/2 the new passcode must not be shared with the customer, as changing installer settings within myenergi devices may inhibit the CLS from proper operation, and failure to follow this advice may result in adverse or even dangerous operation.

8.1 Commissioning Tests and DNO Witness Tests

DNO's will not routinely witness the commissioning tests however, it is important that the commissioning tests required by G100 are completed and a copy of the test results provided to the customer.

The commissioning test actions shall be carried out in the following order:

1. Implement measures to ensure that the MEL or MIL cannot be exceeded.
2. Perform Fail Safe tests, in accordance to section 7.2
3. Verify export and import limits are correct, reconfigure if necessary.

8.2 Fail Safe Tests

Fail-safe tests must be carried out by the installer on commissioning, in accordance with section 5.5 of EREC G100/2. We have provided guidance on how to carry this out, together with a form within Appendix A. This should be completed by the installer and a copy given to the customer.

8.3 Fault Message and Counters

The following messages will be presented on the G100 master device, on detecting an excursion into state 3.

When a user reset is required:

```
G100 Limit Exceeded  
Resets remaining #  
Hold (+) to continue
```

When an installer or manufacturer's reset is required:

```
G100 Limit Exceeded  
Device Locked Out  
Contact myenergi
```



8.4 Clear State 2 and 3 Counters.

To ensure that the customer is left with a fully operational CLS, the state 2 and 3 counters shall be cleared from the master device. To do this enter the installer settings menu with the new passcode, and navigate to Supply Grid > Device > reset G100 counters.

In accordance with G100/2 the new passcode must not be shared with the customer, as changing installer settings settings within myenergi devices may inhibit the CLS from proper operation, and failure to follow this advice may result in adverse or even dangerous operation.

9. User Reset

A local reset of the CLS will be necessary, under the following conditions.

- If the CLS exceeds the MIL or MEL thresholds for greater than 60 seconds,
- If the CLS exceeds the MIL or MEL thresholds for more than 15 seconds but less than 60 seconds, three times in a 24 hour period;
- the time between any two consecutive breaches of the MIL or MEL, for 15 seconds or more, within a 10 minute window.
- If the measured grid current exceeds the state 3 thresholds.

Under these conditions, all connected devices will reduce their active power imported/exported to zero.

It is advisable for the customer to take note of any fault code presented on the master device, before considering if action must be taken, then a reset of the CLS is made by holding the menu button for 3 seconds. The CLS will only permit a reset if the grid current being measured is below the MIL or MEL thresholds, after which normal operation will be allowed.

10. Manufacturer's Lockout

If the CLS has been reset more than 3 times within a rolling 30-day period, then the system will be locked out and normal operation of the devices is not permitted. This is requirement of G100 issue 2 and is aimed at highlighting a potential fault on the customer's local supply and/or with the load or export equipment at the customers premises. Lockout could also be due to incorrect setup.

A warning screen highlighting this will be presented on the master device and will affect all paired devices.

The myenergi app, also shows the following warning each time you access it. To unlock the CLS, either the installer must visit the customers premises and review the system and may unlock the system by clearing the counters, as detailed in section 9.3, else the customer will need to contact myenergi technical support, for further instructions and for remote unlocking of their CLS.

Factors to consider before a manufacturer reset can be made.

- Are the reasons for the lockout fully understood and been addressed?
- Is an installer site visit necessary to conduct additional assessment or testing?



11. Help Centre

If you experience any issues with your myenergi device, please visit our Help Centre by scanning the QR Code or clicking the link below.

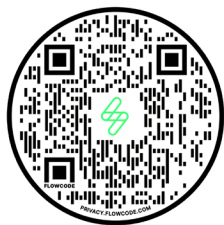

<https://support.myenergi.com/hc/en-gb>

Appendix A

CLS Designation	myenergi eco-system		
Manufacturers name	myenergi Ltd		
Website	www.myenergi.com		
The following section shall be filled out by the installer.			
Installer's Name:		MEL:	Amps
Installer's Business:		MIL:	Amps
Installer Tel:		Master Device with grid connected CT. (model and serial No.):	
Installer Email:			
Customer Name:		Other devices on CLS (model and serial No.):	
CLS Address:			
Installers signature:		Date of commission:	

Table 2 – Fail-safe test procedure

No.	Component	Test	Expected Result	Pass / Fail
1	Connection point component	Remove the G100 grid CT	All devices shall reduce active power to zero in less than 15 seconds.	
2	Principal CLS component	Remove power to the master device	All devices shall reduce active power to zero in less than 15 seconds.	
3	Components controlling generation devices	Remove power to each libbi controller, if present	Generation devices shall reduce active power output to zero in less than 15 seconds.	
4	Components controlling storage devices	Remove power to each libbi controller in-turn, if present	Storage devices shall reduce active power import to zero in less than 15 seconds.	
5	Components controlling load devices	Remove power to each zappi and/or eddi in-turn, if present	Load devices shall reduce active power to zero in less than 15 seconds.	
6	Communication controller and or hubs/switches etc	Remove power to each hub/switch/router used in-turn, if present	If radio communication is operational, then system will continue to function. If this is not setup, all devices, except for master device, will reduce active power to zero in less than 15 seconds.	
7	Communication between components	With WiFi/Ethernet turned off on all devices; turn off radio comms on each device within the CLS in turn.	- Devices without radio comms shall reduce active power to zero in less than 15 seconds. For all other devices with either radio or Ethernet, these will operate normally.	
		Repeat test by turning off radio on all devices; then turn off WiFi/Ethernet on each device within the CLS in turn.	Devices without WiFi/Ethernet shall reduce active power to zero in less than 15 seconds. For all other devices with either WiFi or Ethernet, these will operate normally.	
8	Where applicable, communication between Components and Devices	N/A	N/A	
9	CLS system	With reference to the Manufacturer's published information on internal failures (see 4.5.1.1) undertake the recommended tests etc to confirm that the CLS detects and reacts appropriately to internal failures.	With loss of power to customer supply network, all devices will reduce import and export to zero.	

