

libbi

HOME BATTERY



Model No.

LIBBI-305Sh, LIBBI-310Sh, LIBBI-315Sh, LIBBI-320Sh,
LIBBI-505Sh, LIBBI-510Sh, LIBBI-515Sh, LIBBI-520Sh

Installation Manual

Copyright

Copyright of these instructions remains with the manufacturer. Text and images correspond to the technical level at the time of going to press. We reserve the right to make changes. The content of the operating instructions shall not give rise to any claims on the part of the purchaser. We are grateful for any suggestions for improvement and notices of errors in the operating instructions.

myenergi libbi, myenergi zappi, myenergi eddi, myenergi harvi and myenergi hub are registered trademarks of myenergi ltd.

Liability Limitation

myenergi do not accept any direct or indirect liability for product damage or property loss caused by the following conditions:

- Product modified, design changed or parts replaced without authorisation
- Changes, repair attempts and erasing of serial numbers or seals by an unauthorised person
- System design and installation were not in compliance with standards and regulations; failure to comply with the local safety regulations
- Damage caused by any transportation of the products by the installer
- Failure to follow any and/or all user manuals, installation guides and maintenance regulations
- Improper use or misuse of the device
- Force majeure (stormy weather, lightning overvoltage, fire etc.)
- Damage from external factors

Contents

1. Introduction	4	9. Product Registration (Installer Portal)	27
1.1 Safety	4	10. Product Registration (Customer app and myaccount)	28
1.2 Regulatory Information.....	5	28
2. Product Description	6	11. Commissioning	28
2.1 Product Introduction	6	12. Routine Maintenance & Cleaning	28
2.2 Model Options	6	12.1 Emergency Power Down Procedure.....	29
2.3 Box Contents	7	12.2 Battery Reboot	29
3. System Topologies	8	13. Warranty	29
4. System Appearance	9	14. Help Centre	29
4.1 Battery and Inverter.....	9	14.1 Status, Warning and Fault Codes.....	29
4.2 Controller	10	15. Specifications	32
5. Installation	11	Appendix A – libbi EESS Installation Schematics	34
5.1 Site and Environmental Parameters	11	Appendix B – libbi N-E Bond Relay	35
5.2 Floor Stand Support	12	Appendix C – Setup Wizard Menu Map	36
5.3 Battery	12		
5.4 Inverter	14		
6. Electrical Connections	15		
6.1 Battery and Inverter.....	15		
6.2 Controller	21		
6.3 Fitting the Controller Cover	22		
7. Wiring Overview Diagram	23		
8. Initial Configuration	24		
8.1 Power Up	24		
8.2 Controller Set-up.....	24		
8.3 CT Configuration	24		
8.4 Pairing Devices	24		
8.5 Device Settings.....	25		
8.6 Internet Connectivity	26		
8.7 Export Limitation.....	26		
8.8 Grid Limit.....	27		

1. Introduction

1.1 Safety

Read all the safety instructions. Failure to install and operate the libbi in accordance with these instructions may cause injury or death, damage to the unit or inefficient operation and invalidate the manufacturer's warranty.

The libbi utilises warning signs which contain important information for the system to be operated safely. Ensure these remain undamaged and clear to read. If damaged, warning signs must be replaced immediately.

Manual Keeping

This manual contains important information about operating the system. Before operating, please read it very carefully. The system should be operated in strict accordance with the instructions in this manual. This manual should be kept for future maintenance and reparation for the duration of the products lifecycle.



Indicates a hazardous situation which, if not avoided, could result in death or serious injury.



Indicates a notice or 'tip' to guide you along your install.

DANGER

Danger to life due to high voltages of the PV array, battery and electric shock. When exposed to sunlight, the PV array generates a dangerous DC voltage which will be present in the DC conductors and the live components of the inverter. Touching the DC conductors or the live components can lead to lethal electric shocks. If you disconnect the DC connectors from the system under load, an electric arc may occur leading to electric shock and burns. Therefore, for safety reasons, testing must be carried out with a properly calibrated voltage tester before an installer works on the equipment.

- The inverter can keep a life-threatening voltage even after disconnecting it from the DC and/or AC side
- Do not touch uninsulated cable ends
- Do not touch the DC conductors
- Do not open the inverter and battery
- Do not wipe the system with a wet cloth
- Have the system installed and commissioned by qualified personnel with the appropriate skills only
- Prior to performing any work on the inverter or the battery pack, disconnect the inverter from all voltage sources, as described in this document.

Emergency power down procedure can be found in this document on [page 29](#).

WARNING

Risk of chemical burns from electrolyte or toxic gases. During normal operation, no electrolyte shall leak from the battery pack and no toxic gases shall form. Despite careful construction, if the battery pack is damaged or a fault occurs, it is possible that electrolyte may be leaked or toxic gases formed.

- Do not install the battery and inverter in any environment of temperature below -10°C or over 50°C or in which humidity is over 95%

- Do not install the controller in any environment of temperature below -10°C or over 40°C
- libbi battery and inverter may be sited indoors or outdoors and must be orientated vertically and mounted to a suitable surface or wall
- The controller must be sited indoors and must be orientated vertically and mounted to a suitable surface or wall
- Do not touch the system with wet hands
- Do not put any heavy objects on top of the system
- Do not damage the system with sharp objects
- Do not install or operate the system in potentially explosive atmospheres or areas of high humidity
- Do not mount the inverter and the battery pack in areas containing highly flammable materials or gases
- If moisture has penetrated the system (e.g. due to a damaged enclosure), do not install or operate the system
- When transporting, secure the system to prevent tipping
- The libbi is not to be used by persons (including children) with reduced physical, sensory, or mental capabilities, or lack of experience and knowledge, unless they are supervised or have been given instruction concerning use of the device by a person responsible for their safety
- The transportation of libbi system must be arranged by the manufacturer or instructed personnel, including the Installer. These instructions shall be recorded and repeated
- A certified ABC fire extinguisher with minimum capacity of 2kg must be carried along when transporting
- It is totally prohibited to smoke in or near to the transporting vehicle, at any time
- For the exchange of a battery module, please request for new hazardous goods packaging if needed, pack it and let it be picked up by myenergi or a 3rd party arranged by myenergi
- In case of contact with electrolyte, rinse the affected areas immediately with water and consult a doctor without delay
- Avoid any maintenance to this equipment in adverse weather conditions, when located outdoors

CAUTION

Risk of injury through lifting or dropping the system. The inverter and battery are heavy. There is a risk of injury if the inverter or battery is lifted incorrectly or dropped during transportation or when attaching to or removing from the wall.

Ensure all operations are carried out to the National Manual Handling Guidelines and in accordance with the Manual Handling Operations Regulations 1992.

- Lifting and transporting the inverter and battery must be carried out by a minimum of 2 people
- The system should be operated in strict accordance with the instructions in this manual. This manual should be kept for future reference for any maintenance and reparation.

1.2 Regulatory Information

General

This product complies with the applicable CE and UKCA marking directives / statutory instruments and harmonised /designated standards:

- Radio Equipment (RED: Directive 2014/53/EU & SI 2017 No. 1206)
- Electromagnetic Compatibility (EMC: Directive 2014 / 30/ EU & SI 2016 No. 1091)
- Low Voltage (LVD: Directive 2014/35/EU & SI 2016 No. 1101)

A copy of the Declaration of Conformity is available in the Download Centre on the myenergi website here; <https://www.myenergi.com/installers-centre/download-centre/>

Electromagnetic Compatibility (EMC)

This equipment has been designed and tested to fulfil applicable standards for:

- Radio frequency emissions when installed according to the instructions and used in its intended environment.
- Immunity to electrical and electromagnetic phenomena when installed according to the instructions and used in its intended environment.

This equipment generates, uses, and can radiate radio frequency energy and, if not installed and used in accordance with this instruction manual, may cause harmful interference to radio communications. Modifications not expressly approved by the manufacturer could void the user's authority to operate the equipment under EU rules.

Electrical Safety

The libbi controller is designed for 230Vac \pm 10%. A suitable capacity fuse, maximum 3A, shall be located in the supply. Supply wiring must be 2mm min, 300V minimum rated. Wiring shall be installed without stress and free from being scratched by sharp objects. The unit shall be electrically grounded via the earth point(s) provided.

The inverter input must not exceed 580Vdc. libbi is designed to be used at less than 2000m above sea level.

Radio Equipment

This device incorporates a 868/915MHz radio and 2.4GHz wireless transmitter, and complies with EN62311 for risks to human exposure.

Radio operates in bands between 868–870MHz / 915–916.3MHz – 25mW max.

WiFi operates between 2412-2484 MHz (802.11 b/g/n) - 100mW max.

Grid Compliance

When installed, libbi operates the following grid compliant modes:

G98/G99/G100

DIN VDE 0126-1-1;

VDE-AR-N-4105;

G100 Guidance

libbi supports the Customer Import and Export Limitation Scheme (CLS), in accordance with G100 issue 2. Where G100 is required as part of an installation, then the installer must adhere to the **G100 Commissioning Guidance** document which can be located here:

<https://www.myenergi.com/installers-centre/download-centre/>

Once the CLS is setup correctly, the master device within the myenergi eco-system will monitor the maximum import and export, and if necessary, instruct other devices to increase or decrease import or export if these maximum thresholds are ever exceeded.

Battery Safety Information

This product is a Lithium Iron Phosphate Battery with certified compliance under the UN Recommendations on Transport of Dangerous Goods, Manual of Tests and Criteria, Part III, subsection 38.3. For battery cell, chemical materials are stored in a hermetically sealed metal case, designed to withstand temperatures and pressures encountered during normal use. As a result, during normal use, there is no physical danger of ignition or explosion and chemical danger of hazardous materials' leakage. However, if the product is exposed to fire, mechanical shocks or electric stress by misuse, the gas release vent will be opened. The battery cell case will be breached at the extreme. Hazardous materials may be released. Moreover, if heated strongly by the surrounding fire, acid or harmful fumes may be emitted.

Product Information Sheet

For detailed information please refer to the Product Information Sheet which can be found on the myenergi website.

Disposal

In accordance with European Directive 2012/19/EU on waste electrical and electronic equipment and its implementation in national law, used electrical devices must be collected separately and recycled in an environmentally responsible manner. Ensure that you return your used device to myenergi or obtain information regarding a local, authorised collection and disposal system. Failure to comply with this EU Directive may result in a negative impact on the environment.

Moisture Protection

If the internal mechanisms of the battery, inverter or controller were exposed to moisture this would likely cause damage. Avoid any repairs or maintenance activities outdoors in adverse weather conditions.

Operation after power failure

The battery system is part of the energy storage system which stores life-threatening high voltage current (even when the DC side is turned off). Touching the battery outlets is strictly prohibited. The inverter can keep a life-threatening voltage even after disconnecting it from the DC and /or AC side. Therefore, for safety reasons, it must be tested with a properly calibrated voltage tester before an installer works on the equipment.

2. Product Description

2.1 Product Introduction

These instructions will help you to familiarise yourself with the libbi energy storage system. By reading these instructions, you will have all the information needed to help your customer get the maximum benefit from their new 'eco-smart' device.

libbi is an energy storage system that enables surplus energy produced by a PV array, or other renewable generation, to be stored for a home's future use, instead of being exported back out to the grid. It can also be installed in homes where no generation is installed, to maximise the benefits of off-peak Time of Use Tariff prices.

libbi can be installed as a standalone product, but will work in conjunction with other myenergi products: zappi, eddi, harvi, for a super 'eco-smart' home.



If installing alongside existing myenergi devices, existing devices **MUST** be updated to the latest firmware before pairing libbi. It is a good idea to start the updates on these before you begin your libbi install.



libbi is **NOT** compatible with zappi V1

2.2 Model Options

libbi comes in various system sizes from 5.1kWh to 20.4kWh. It is modular by design which means a 5.1kWh system can easily be upgraded to up to 20.4kWh, if required.

libbi has the option of 2 inverters; a 3.68kW and a 5kW. You will need to decide which option is most suited to the install specific requirements.

Model No. LIBBI-305Sh

Inverter Size: 3.68kW

Battery Capacity: 5kWh



Model No. LIBBI-310Sh

Inverter Size: 3.68kW

Battery Capacity: 10kWh

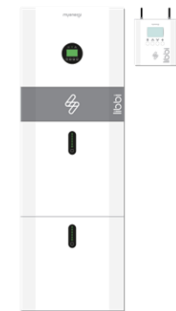

Model No. LIBBI-315Sh

Inverter Size: 3.68kW

Battery Capacity: 15kWh

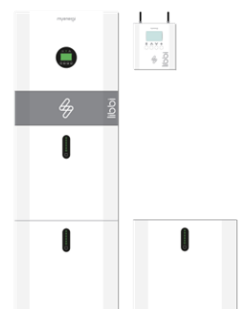

Model No. LIBBI-320Sh

Inverter Size: 3.68kW

Battery Capacity: 20kWh



Model No. LIBBI-505Sh

Inverter Size: 5kW

Battery Capacity: 5kWh



Model No. LIBBI-510Sh

Inverter Size: 5kW

Battery Capacity: 10kWh

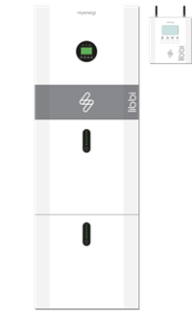

Model No. LIBBI-515Sh

Inverter Size: 5kW

Battery Capacity: 15kWh

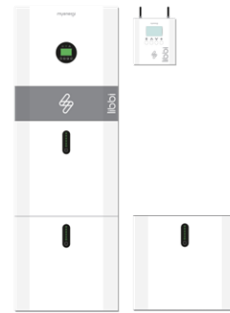

Model No. LIBBI-520Sh

Inverter Size: 5kW

Battery Capacity: 20kWh



2.3 Box Contents

Part Code	Description	LIBBI-305Sh	LIBBI-310Sh	LIBBI-315Sh	LIBBI-320Sh	LIBBI-505Sh	LIBBI-510Sh	LIBBI-515Sh	LIBBI-520Sh
LIBBI-HS3680	3.68kW Inverter	✓	✓	✓	✓				
LIBBI-HS5000	5kW Inverter					✓	✓	✓	✓
LIBBI-B05h	5kWh Battery Module	x1	x2	x3	x4	x1	x2	x3	x4
LIBBI-C110W	Controller	✓	✓	✓	✓	✓	✓	✓	✓
LIBBI-EK051	Cable Pack for 5kWh System	✓				✓			
LIBBI-EK101	Cable Pack for 10kWh System		✓				✓		
LIBBI-EK151	Cable Pack for 15kWh System			✓				✓	
LIBBI-EK201	Cable pack or 20kWh System				✓				✓
LIBBI TP1	Top Panel	N/A	N/A	Opt. ¹	Opt. ¹	N/A	N/A	Opt. ¹	Opt. ¹
LIBBI-FS01	Floor Stand Support	Opt. ²	Opt. ²	Opt. ³	Opt. ³	Opt. ²	Opt. ²	Opt. ³	Opt. ³

N/A - Not applicable.

1 - Optional top panel cover for 15 and 20kWh systems.

2 - Optional Floor Stand Support to ensure a level surface for mounting battery stack.

3 - Optional Floor Stand Support to ensure a level surface for mounting battery stack. Two required for 15 and 20 kWh Systems.

Breakdown of individual Part Codes below:

LIBBI-HS3680 Inverter

Description	Quantity
3.68kW Inverter	1
M5 x 12mm Bolt	4
ST6.3 x 50mm Screw	2
D10 x 50mm Wall Plug	2
Backup Connector	1
AC Connector	2
MC4 Connector (Pair)	2
Inverter Mounting Panel	1

LIBBI-HS5000 Inverter

Description	Quantity
5kW Inverter	1
M5 x 12mm Bolt	4
ST6.3 x 50mm Screw	2
D10 x 50mm Wall Plug	2
Backup Connector	1
AC Connector	2
MC4 Connector	2
Inverter Mounting Panel	1

LIBBI-B05h Battery Module

Description	Quantity
5.12kWh Battery Module	1
M5 x 12mm Bolt	2
ST6.3 x 50mm Screw	4
D10 x 50mm Wall Plug	4
M6 Washer	4
Battery Mounting Panel	1

LIBBI-C110W Controller

Description	Quantity
Controller	1
RS485 Cable (5 metres)	1
CT Clamp and cable (5 metres)	1
Radio Antenna	1
WiFi Antenna	1

LIBBI-EK051 Cable Pack for 5kWh System

Description	Quantity
Communication Cable - 300mm	1
Power Cable-Negative (Black) - 250mm	1
Power Cable-Positive (Red) - 250mm	1
PE Cable - 700mm	1

LIBBI-EK101 Cable Pack for 10kWh System

Description	Quantity
Communication Cable - 300mm	1
Communication Cable - 570mm	1
Power Cable-Negative (Black) - 250mm	1
Power Cable-Negative (Black) - 485mm	1
Power Cable-Positive (Red) - 485mm	1
Power Cable-Positive (Red) - 1200mm	1
PE Cable - 520mm	1
PE Cable - 700mm	1

LIBBI-151 Cable Pack for 15kWh System

Description	Quantity
Communication Cable - 300mm	1
Communication Cable - 570mm	1
Communication Cable - 1700mm	1
Power Cable-Negative (Black) - 250mm	1
Power Cable-Negative (Black) - 485mm	1
Power Cable-Negative (Black) - 1800mm	1
Power Cable-Positive (Red) - 485mm	1
Power Cable-Positive (Red) - 1900mm	1
Power Cable-Positive (Red) - 2800mm	1
PE Cable - 520mm	1
PE Cable - 700mm	1
PE Cable - 1700mm	1

LIBBI 201 Cable Pack for 20kWh System

Description	Quantity
Communication Cable - 300mm	1
Communication Cable - 570mm	2
Communication Cable - 1700mm	1
Power Cable-Negative (Black) - 250mm	1
Power Cable-Negative (Black) - 485mm	2
Power Cable-Negative (Black) - 1800mm	1
Power Cable-Positive (Red) - 485mm	2
Power Cable-Positive (Red) - 1900mm	1
Power Cable-Positive (Red) - 3300mm	1
PE Cable - 520mm	2
PE Cable - 700mm	1
PE Cable - 1700mm	1

LIBBI-TP1 Top Panel

Description	Quantity
Top Panel	1

LIBBI-FS01 Floor Stand Support

Description	Quantity
Floor Stand Support	1

3. System Topologies

libbi is an energy storage system that enables surplus energy produced by PV, or other renewable generation, to be stored for future use in the home, rather than being distributed back out to the grid. libbi can be installed as a standalone product or will work in conjunction with other myenergi products; zappi, eddi, harvi, for a super 'eco-smart' home.

libbi uses a hybrid inverter so can be used with AC Coupled or DC Coupled battery systems. An option of 5kW or 3.68kW inverter paired with a minimum of 1 and maximum of 4, 5.1kWh battery storage units per inverter.

3.1 Overview Diagrams

The following diagrams show the libbi working as an AC, DC or Hybrid Coupled Battery System.

AC-Coupled Battery System

- Usually retrofit systems where existing PV is in place with a separate inverter or;
- where there are no other forms of generation

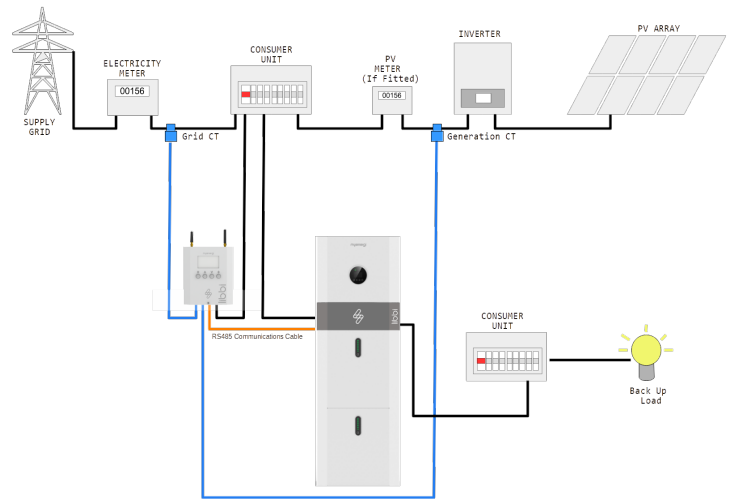

DC-Coupled Battery System

- Ideal when a customer is looking for PV and backup battery storage at the same time (cost saving).

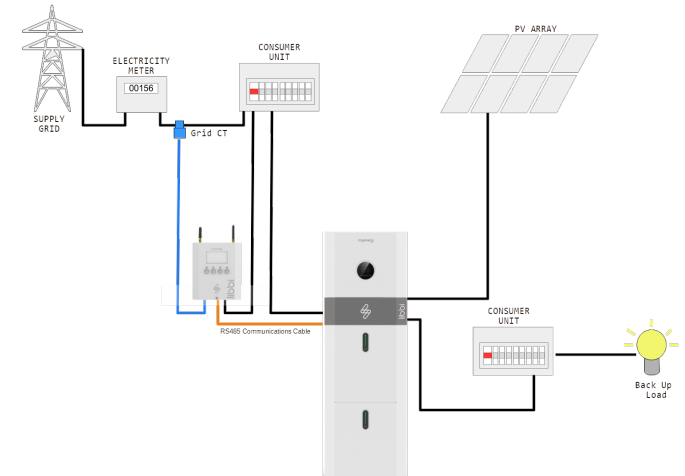

Hybrid Coupled Battery System

- Retrofit system where a customer already has PV and existing inverter and they have further PV installed alongside libbi but keep their existing inverter for their existing PV

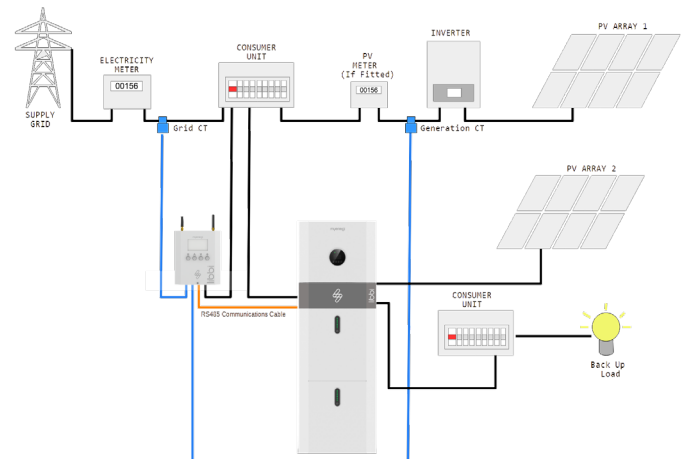

4. System Appearance

4.1 Battery and Inverter

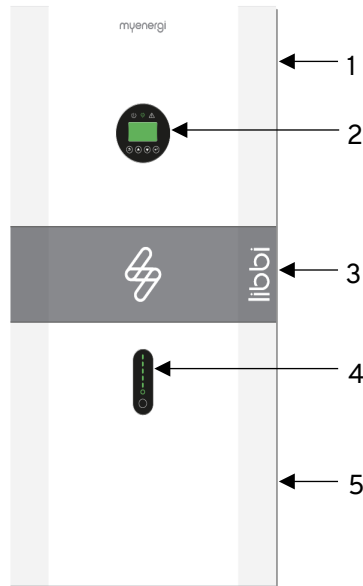

1.	Hybrid Inverter LIBBI-HS3680/HS5000
2.	On Board Display
3.	Cable Box (connected to inverter)
4.	Battery Capacity Indicator
5.	5.1kWh Battery Cell (Battery 1)

Inverter On Board Display and Light Indicators

You will be controlling your system using the libbi controller and the myenergi app so it isn't necessary to go into the inverter on board display menu.

However, we describe below what you can expect to see on your inverter display and what those light indicators mean.



Icon	LED	What does it mean?
	Green	A solid green light indicates libbi is on and there is a grid connection.
	Green (Flashing)	A flashing green light indicates libbi is in standby.
	Green	A solid green light indicates there is an off-grid connection.
	Red	A solid red light indicates there is a system fault. See libbi controller display for fault code.

The display itself will continuously run through information screens whilst the unit is on. The screens you can expect to see are below.

BMS PARAM		STATE		ERROR NO.	
TYPE:	LFP	SYS:	STANDBY	WARNING:	W04-1
TEMP:	17.4°C	INV:	STANDBY	FAULT:	XXX-X
SOC:	11.0%	DCDC:	SOFT STAR		
TEMPERATURE		BMS PARAM		BATTERY	
INV:	22.8°C	CHAR VOLT:	56.1V	VOLT:	51.63V
DCDC:	22.4°C	CHARGE:	50A	CURR:	-3.8A
AMBIENT:	26.0°C	DISCHARGE:	81A	CAPACITY:	100Ah
POWER		INV DATA		GRID DATA	
PV:	W	VOLT:	242.1V	VOLT:	241.7V
BACKUP:	W	CURR:	2.13A	CURR:	0.00A
BAT:	-560W	FREQ:	49.99Hz	FREQ:	49.98Hz
POWER		SYSTEM		DC VOLTAGE	
INV:	-641W	STATE:	PK SHIFT	BUS:	383.8V
GRID:	W	GRID:	U.K.		
LOAD:	W	PV I/P:	INDEPEN		
BACKUP DATA		PV2 INPUT		PV1 INPUT	
VOLT:	243.5V	VOLT:	6.1V	VOLT:	5.4V
CURR:	0.00A	CURR:	0.00A	CURR:	0.00A
		POWER:	W	POWER:	W



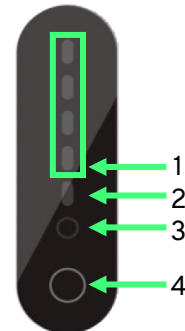

Battery Light Indicators

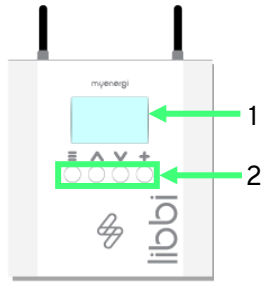

1.	Capacity Indicator – Each green light represents 25% of battery capacity. If solid green this indicates this section is full. If flashing green this indicates this section is currently charging. i.e. two solid green lights with a third flashing green light indicates 50% capacity is full and 51-75% is currently charging.
2.	Fault Indicator – Lights up red to indicate a fault with the system. See controller display for further information. Note: When switching the system on and off this light will show as red momentarily and then turn off.
3.	Running Light – A solid green light indicates the system is on. This will become a flashing green light when the battery is charging and discharging.
4.	Reset Button – For resetting the battery.

4.2 Controller



1. Display	Graphical LCD display with LED backlight
2. Control Buttons	Four tactile buttons to navigate the menus and alter settings: <ul style="list-style-type: none"> Enter menu (from main screen) Exit current menu Move up a menu item Increase value Move down a menu item Decrease value Select item Confirm value and move to next setting

5. Installation

5.1 Site and Environmental Parameters

Battery and Inverter

This libbi battery & inverter has been engineered to IP65 and can be installed in an outdoor location.

If installed indoors in a room, libbi must be installed in an accessible location and remain unblocked by the structure of the building, the furnishings and equipment of the room.

The location should be clean, dry and adequately ventilated.

The following locations are not allowed for installation:

- Habitable rooms, such as a living room or bedroom
- Ceiling cavities or wall cavities
- On roofs that are not specifically considered suitable
- Access / exit areas or under stairs / access walkways
- Locations with humidity and condensation over 95%
- Places where salty and humid air can penetrate;
- Seismic areas - additional security measures are required
- Sites with altitude over 2000m
- Locations with direct sunlight or a large change in the ambient temperature
- Places with flammable materials or gases or an explosive atmosphere
- libbi must be stood on a stable, flat surface at floor level.

The installation clearance requirements for the battery/inverter are as follows:

- In restricted locations as defined by local regulations, where applicable.
- 600mm either side and in front, from any other device or object (including exits and windows or air vents)
- 500mm from ceiling.¹
- 200-300mm distance between stacks
- The highest point of the libbi inverter must not be more than 2.2m from ground level
- If installed in a corridor, hallway or lobby you must leave a safe egress of at least 1 metre
- If installed on a wall that is the barrier to a habitable living area, the wall must be made of non-combustible material OR a non-combustible barrier must be installed before mounting the libbi to it.
- If installed in any corridor, hallway, lobby or the like and leading to an emergency exit, sufficient clearance for safe egress of at least 1 metre should be left.

The distance between stacks is solely to allow enough room to open the battery side panels. The other dimensions are safety parameters to protect against the spread of fire

Front View

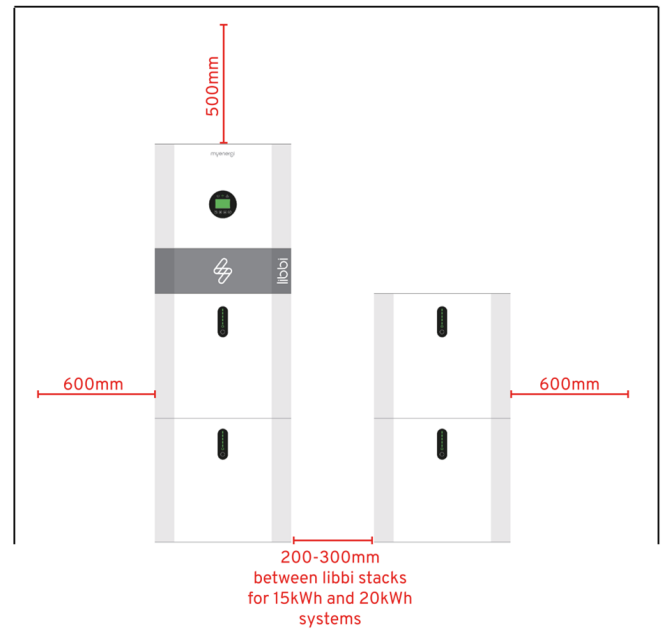

Side View

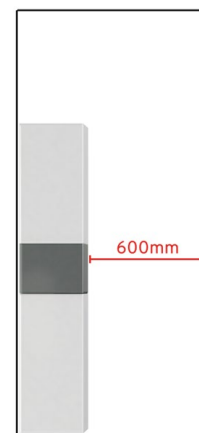

If the gap between the top of the inverter and the ceiling is less than 600mm, the ceiling and any wall within a 600mm radius must be made of non-combustible material.

■ Non-combustible material

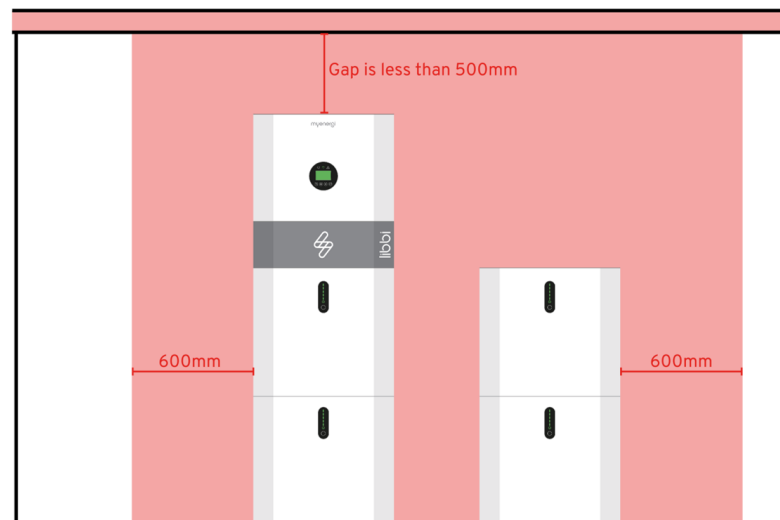

¹If there is less than 500mm distance between the top of the libbi system and the ceiling then, the ceiling and any wall within 600mm radius must be made of non-combustible material (see diagram adjacent)

Side View - Corridor leading to an emergency exit

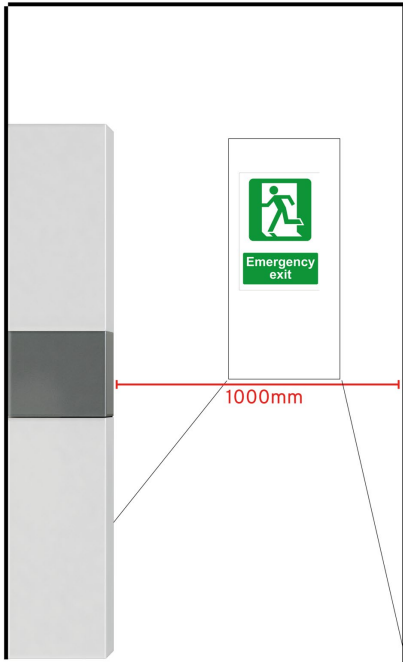

Habitable living space

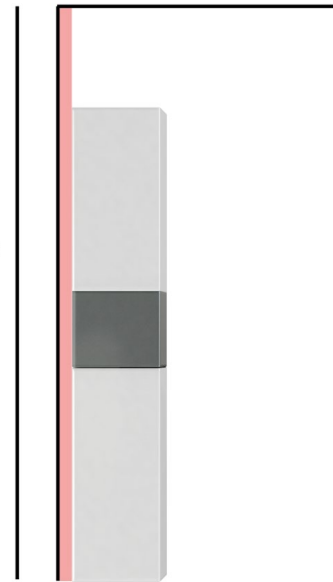

Non-combustible barrier installed before installing libbi

Side View - Barrier to habitable room

Non-combustible material

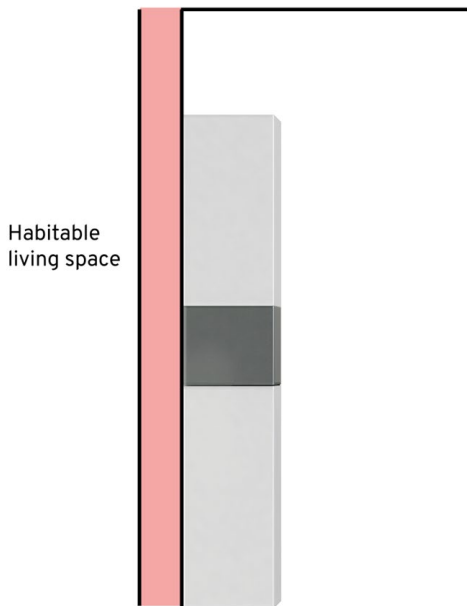

Non-combustible adjoining wall

Controller

The libbi controller must NOT be installed outdoors.

When siting the controller it will be useful to take into account the following:

- Must be installed indoors and to local building regulations
- Distance of controller from the battery & inverter (communication cable length will depend on this, up to a max. of 100 metres)
- Distance between the controller and other myenergi devices (if applicable)

5.2 Floor Stand Support

If using the libbi floor stand support, place in the location of where you will be installing the battery and ensure it is level.

libbi must be installed on a level surface so, if you are not utilising the libbi stand support option available, we would suggest using shim quick align hinges, if necessary.

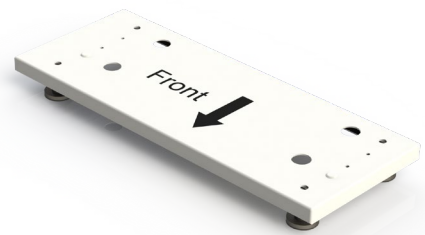

5.3 Battery

CAUTION ⚠

The battery must be handled by 2 persons and carried by the lifting handles, as shown.

It is the installer's responsibility to ensure they are applying correct manual handling procedures throughout the install process.

- 1) Remove the battery/batteries from the packaging. Ensure all accessories are taken from the boxes and kept to hand for use later.
- 2) Attach the battery mounting panel to the back of the battery using the two M5 x 12mm screws, provided.

Lifting Points

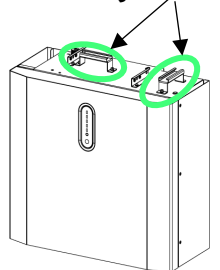

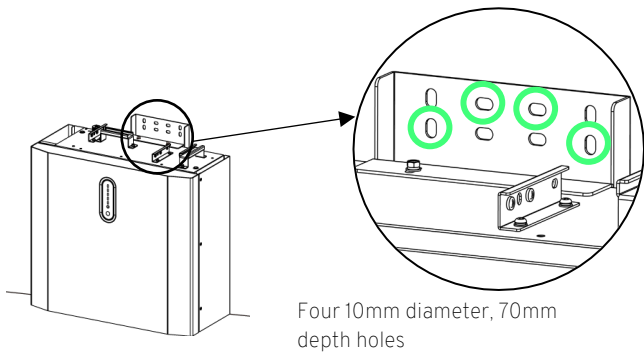

- 3)** Position battery parallel to flat wall and make markings, using a pencil or pen, on the wall where the fixings will go. Then, undo the two M5 screws to detach the battery mounting bracket.

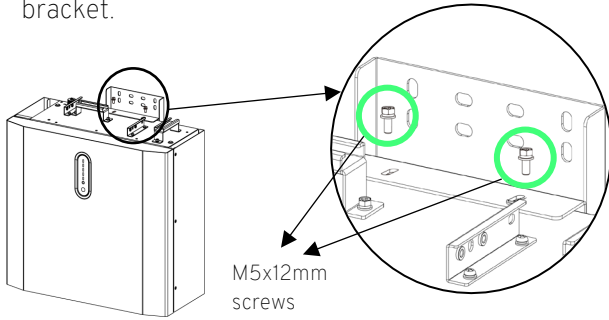

- 4)** Remove the handle on the left top side of the battery for easier access. Keep this safe as you will replace it later.
- 5)** In each place you have marked on the wall, use an 10mm diameter drill, to create four holes to the depth of approximately 70mm.



Depending on wall build up you may be required to supply your own suitable fixings.

- 6)** Insert the four wall plugs provided into each hole.
- 7)** Re-attach the battery mounting panel as you did in step 2.
- 8)** This step differs depending on install specific criteria. Read the 3 options below carefully, before moving forward and securing anything to the wall.

Option 1: If you are installing a 5.1kWh system (1 battery)

Take two M6 washers and two ST6.3x50mm screws, one at a time, place the washer against the front of the battery mounting bracket before inserting the screws into the two bottom outside holes to secure the mounting panel to the wall, as depicted adjacent.

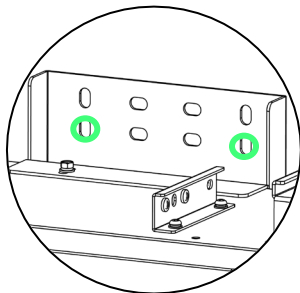

Option 2: If you are installing a 10.2kWh system (2 batteries) AND this is the first of the two

Take four M6 washers and four ST6.3x50mm screws, one at a time, place the washer against the front of the battery mounting bracket before inserting the screws into the two bottom outside holes to secure the mounting panel to the wall, as depicted adjacent.

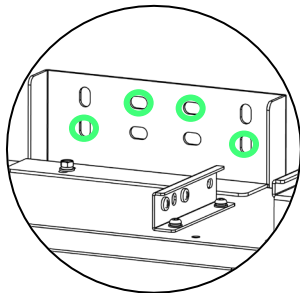

Option 3: If you are installing a 10.2kWh system (2 batteries) AND this is the second of the two

Take two M6 washers and two ST6.3x50mm screws, one at a time, place the washer against the front of the battery mounting bracket before inserting the screws into the two bottom outside holes to secure the mounting panel to the wall, as depicted adjacent.

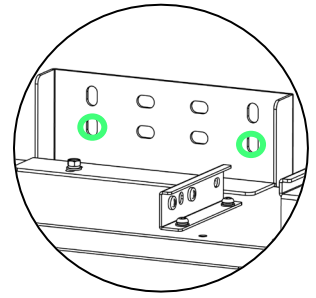

Washer should be placed on the front of the mounting panel, as shown below.

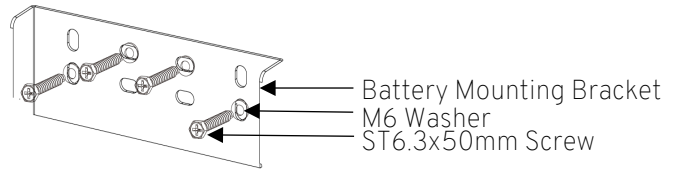

- 9)** For a 10.2kWh system (2 batteries), sit the second battery on top of the first and follow steps 2-8 again.



If installing a 1 or 2 battery system, skip ahead to section 5.4. If installing a 3 or 4 battery system or upgrading to a 3 or 4 battery system, please follow the next steps carefully.

- 10)** For a 15kWh system (3 battery) your third battery will create a new stack. Follow steps 2-8 again, treating a third battery the same as you would for the first battery of a 10kWh system.

- 11)** For a 20kWh system (4 battery) your fourth battery will sit on top of your new stack. Follow steps 2-8 again treating a fourth battery the same as you would for the first battery of a 10kWh system.

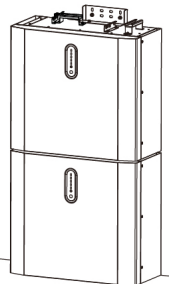

- 12)** Attach top cover to second battery stack, if installing a 3 or 4 battery system.

- 13)** Before progressing to the next section you should now have all batteries assembled/installed. Please ensure your install looks like one of the configurations below, depending on system, before proceeding to the next stage.



NEVER install more than 2 batteries, vertically.

**5.1kWh System
(1 battery)**



**10.2kWh System
(2 batteries)**

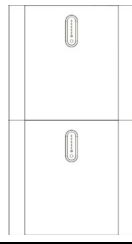

**15.3kWh System
(3 batteries)**

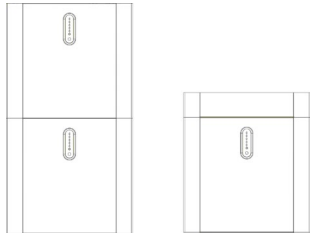

**20.4kWh System
(4 batteries)**

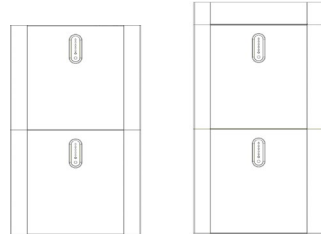

5.4 Inverter

Whether you have the 3.68kW or 5kW inverter, installation will be the same.

- 1) Remove the inverter from its packaging. Ensure all accessories are taken from the boxes and kept to hand for later use.
- 2) Take the inverter mounting bracket and align the two bottom holes with the two middle top holes of the battery mounting panel. Ensure the inverter mounting bracket is level with the wall, then make markings on the wall for the two top holes.
- 3) Using an 10mm diameter drill, create two holes, where you have just marked the wall, to the depth of approximately 70mm and then insert the wall plugs provided.

- 4) One at a time, with the four remaining M6 washers and the four remaining ST6.3x50mm screws, place the M6 washer against the front of the inverter in line with the hole, then insert an ST6.3x50mm screw. Continue until you have tightened all four holes; two at the top of the inverter bracket and the two middle holes at the bottom overlapping the battery mounting bracket and the inverter mounting bracket. As shown in the image to the right.

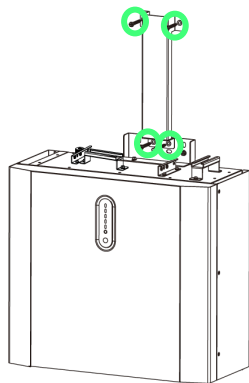

- 5) Remove the cable box cover by loosening the two thumbscrews on either side at the back of the cover, as shown below.

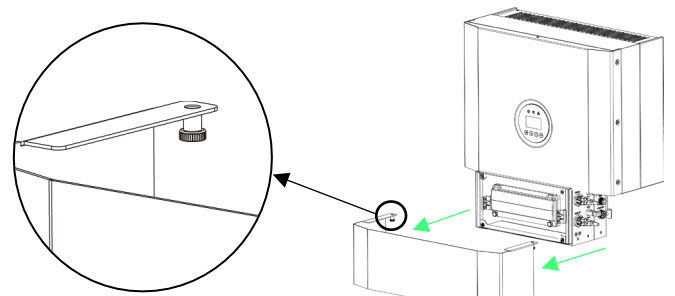

- 6) Hang the inverter onto the inverter mounting bracket and adjust to align with the battery(ies).

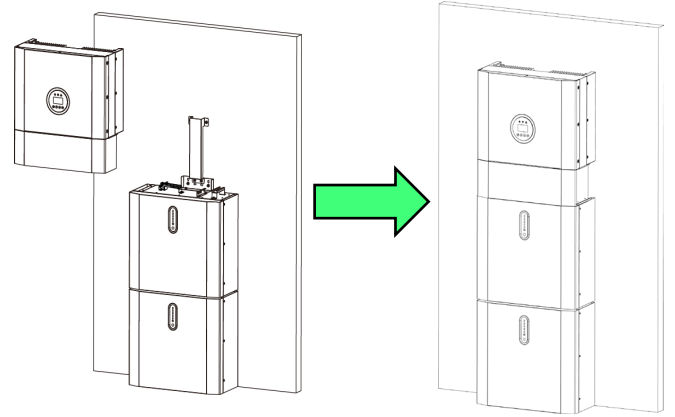

- 7) Take the four M5x12mm bolts provided and insert them through the bracket holes shown below and loosely tighten to secure the inverter to the battery, on both the left and the right side.

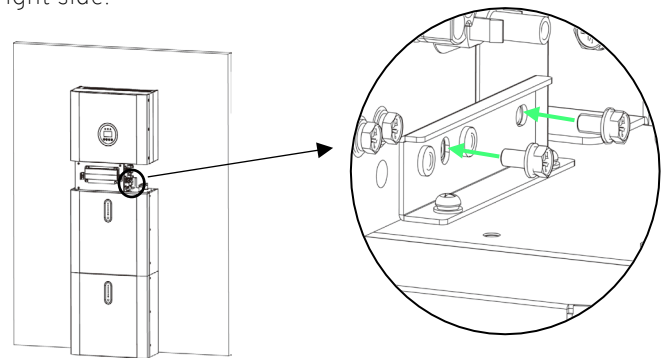

5.5 Controller



libbi controller is not suitable for installation outdoors.

Ensure the device always has adequate ventilation; do not block the vents or obstruct airflow at the back of the unit.

- 1) With the unit on its back on a flat surface, remove the front cover by unscrewing the Torx screw (1) and lifting off, in a tilting motion, from the bottom edge upwards.

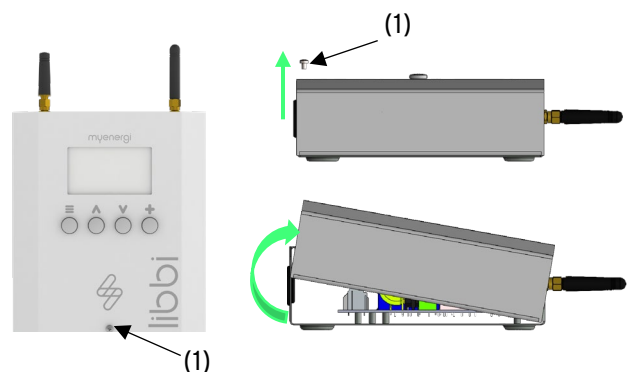

- Place the back of the controller against the wall where you will be installing the device, ensure level and then mark the three holes (2) onto the wall, in preparation for drilling.

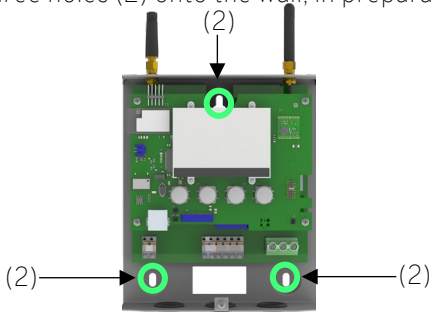

- Using a drill, make three holes to the correct depth, according to the suitable fixings, provided by you.
- Insert three screws and tighten to secure the controller to the wall's surface.

6. Electrical Connections

WARNING

ELECTRIC SHOCK – An electric shock can be fatal; electrical connection work may only be carried out by a competent person.

6.1 Battery and Inverter



The method of anti-islanding protection is power variation.

- The Cable Box Cover will already have been removed during section 5.4. Now you need to open the plastic switch cover by undoing the two thumb screws, as shown below.

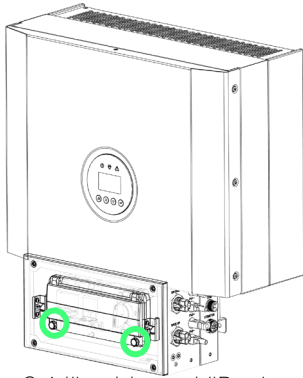

- Make up the "On Grid" cable and "Backup" cable if used, as per steps (a-f):

WARNING

There are "L", "N", and "⊥" symbols marked inside the connector, the line wire of grid must be connected to "L" terminal; the neutral wire of grid must be connected to "N" terminal; the earth of grid must be connected to "⊥".



Please adhere to local wiring regulations when selecting the type and size of cable to be used.



In order to keep within the warranty parameters of libbi, the AC supply must be connected to the cable box using the provided plug. The plug must not be bypassed by wiring directly into the cable box.



If you are using the backup function, the main supply cable into the libbi inverter should be suitably sized to cope with the battery charging at full rate & the full load connected to the backup circuits, simultaneously.

Object	Description	Value
A	External diameter	12mm to 18mm
B	Copper conductor cross-section	4mm ² to 10mm ²
C	Stripping length of the insulated conductors	Approx. 13mm
D	Stripping length of the outer sheath of the AC cable	Approx. 53mm
The PE conductor must be 10mm longer than the L and N conductors		

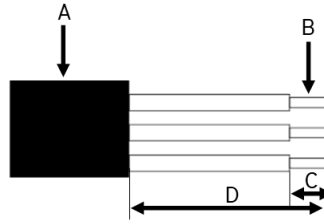

- Prepare the cable in accordance with the detail above. If using stranded conductors, apply and crimp suitable ferrules according to DIN 46228-4 to each of the conductors.



- Unscrew the plug provided. Then, thread the swivel nut and threaded sleeve over the AC cable.

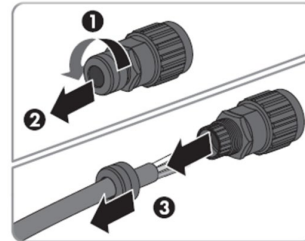

- Insert the crimped conductors L, N and PE into the corresponding terminals and tighten the screw with a hex key wrench screwdriver.

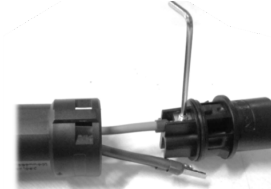

- Screw the swivel nut onto the threaded sleeve. This seals the AC connector and provides strain relief for the AC cable. This ensures that the swivel nut can be screwed firmly onto the threaded sleeve.

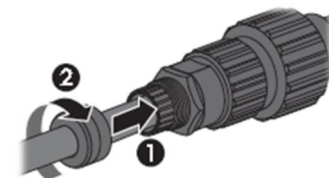

- Push the two plug parts together until a 'click' is heard.

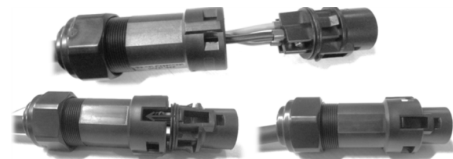

- Lock the swivel nut in place by screwing shut. Then, connect the AC plug into the terminal on the external right side of the cable box. Push by hand until you hear a 'click'.

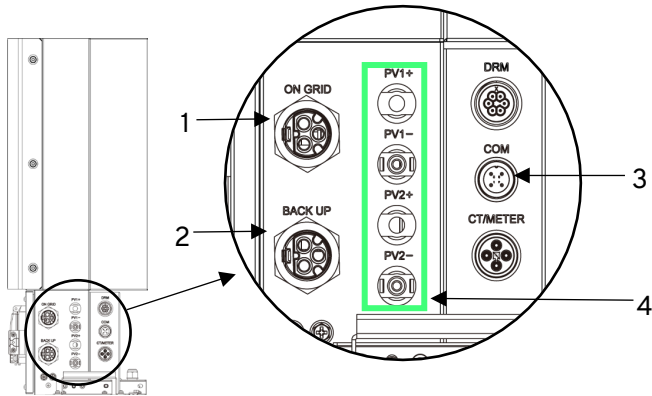
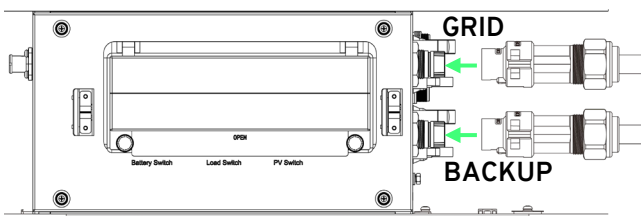

- | | |
|----|---|
| 1. | AC External Connection (on grid) |
| 2. | Back Up Supply Connection |
| 3. | RS485 Controller Communication Connection (COM) |
| 4. | PV Connections |

Backup connections

For back-up connection follow steps a) to f) again.

The backup CCT must be installed into a separate, dedicated consumer unit.

Type A RCD must be installed on the backup supply.

The backup CCT is protected by a 32A MCB (BS EN 60898) within the inverter cable box.

A separate earthing arrangement must be installed, when connecting the backup.

If you are using the backup function, the main supply cable into the libbi inverter should be suitably sized to cope with the battery charging at full rate & the full load connected to the backup circuits, simultaneously.

i.e. 3.68kW inverter plus 3.68kW backup circuit load would require cable sufficient to cope with 7.36kW total.

- 3) **Connecting PV.** If connecting PV Generation, make up the MC4 plugs by following steps a) to e):

The supplied MC4 plugs are one time use only. Please ensure you fully understand how to make up the plug before beginning.

PV supply can be wired directly into the libbi inverter.

MC4 plugs are supplied with the libbi and **MUST** be used for PV connections to the inverter.

When installing libbi alongside PV, you must fit external DC isolators to the PV strings, to allow maintenance of the inverter.

libbi has positive and negative terminations for up to two inputs. However, PV strings are NOT required to be split, you may utilise only one or both the negative/positive inputs.

- Strip the cable, ensuring crimped section of cable can fit within respective fixing area.
- Crimp the fixings.
- Push fixings into their respective plug, until a "click" is heard.
- Screw the sleeves onto the plug, until flush.
- Insert both the positive and negative connections into the respective terminal on the side of the inverter.

- 4) **Connecting the battery(ies).** Take the negative (black) and positive (red) battery power cables and connect into the terminals on the left hand side of the inverter, as shown below. **Black to (-), Red to (+).** Follow instructions in step 5) which will guide you through each system model.

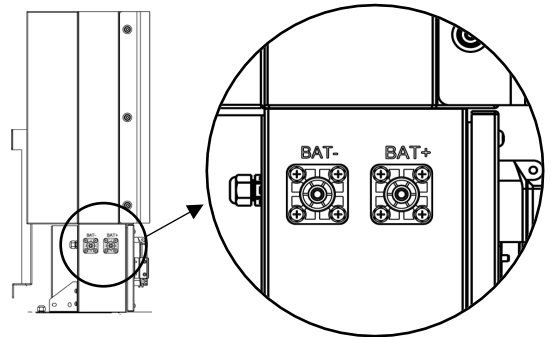

- 5) Remove screws from the battery module side panels and open. Then, follow the instructions on the next page, depending on which size system you are installing.

5.1kWh (1 battery) System

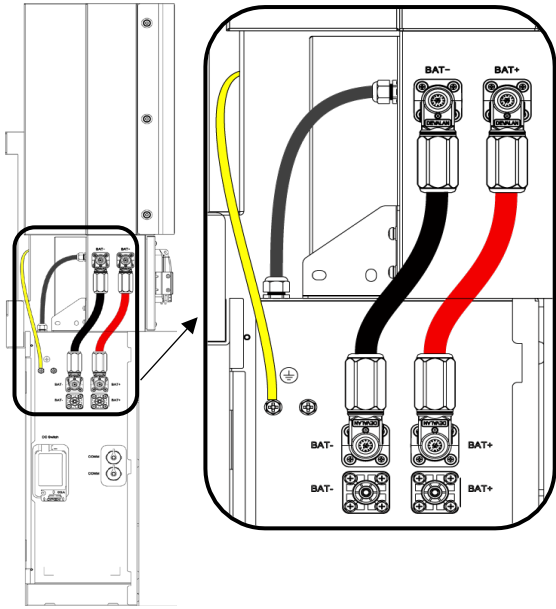

Cable Pack for 5.1kWh (1 Battery) System Communication

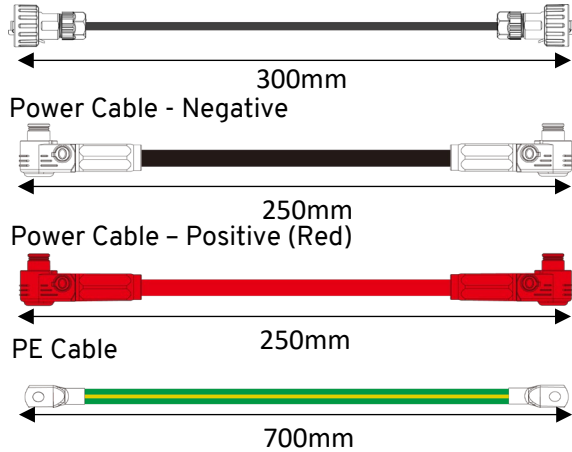

- Insert the black battery power cable (250mm) into the negative terminal on the left side of the inverter. Then, insert the other end into the top negative terminal on the left side of the battery.
- Insert the red battery power cable (250mm) into the positive terminal on the left side of the inverter. Then, insert the other end into the top positive terminal on the left side of the battery.
- Insert the grey/black communication cable (300mm) into the terminal on the left side of the inverter. Insert the other end into the communication terminal on the top of the battery.
- Connect the PE Cable (700mm) to the earth connection of the inverter, left side. Connect the other end to the earth connection on the left side of the battery.

10.2kWh (2 battery) System

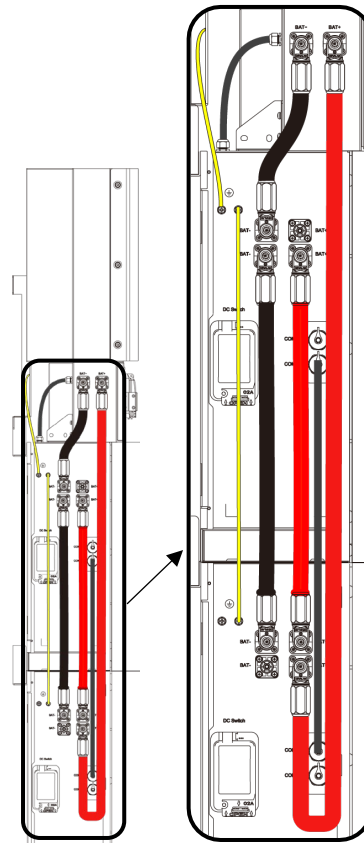

Cable Pack for 10.2kWh (2 Battery) System Communication

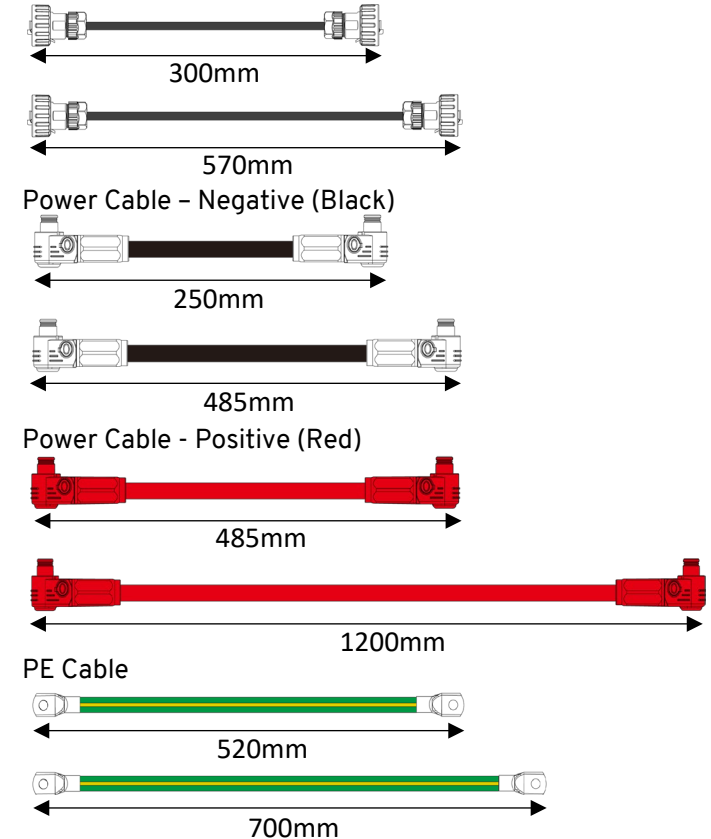

- a) Insert the black battery power cable (250mm) into the negative terminal on the left side of the inverter. Then, insert the other end into the top negative terminal on the left side of the battery.
- b) Insert the black battery power cable (485mm) into the bottom negative battery terminal of your first battery. Then, insert the other end into the top negative battery terminal of the second battery.
- c) Insert the red battery power cable (1200mm) into the positive terminal on the left side of the inverter. Then, insert the other end into the bottom positive terminal on the left side of the second battery.
- d) Insert the red battery power cable (485mm) into the top positive battery terminal of the second battery. Then, insert the other end into the bottom positive battery terminal of the first battery.
- e) Insert the grey/black communication cable (300mm) into the terminal on the left side of the inverter. Insert the other end into the communication terminal on the top of the first battery.
- f) Insert the grey/black communication cable (570mm) into the bottom COM terminal of the first battery. Then, insert the other end into the top COM terminal of the second battery.
- g) Connect the PE Cable (700mm) to the earth connection on the left side of inverter. Connect the other end to the earth connection on the left side of the top battery.
- h) Connect the PE cable (520mm) to the earth connection on the left side of the first battery. Then connect the other end to the earth connection on the left side of the second battery.



Negative Battery Power Cable (Black), PE Cable and Communication Cable always go sequentially from inverter to first battery, to second battery and so on.

Positive Battery Power Cable (Red) has to have a reverse loop, this will always go from inverter to the last battery and work its way backwards.

15.3kWh (3 battery) System

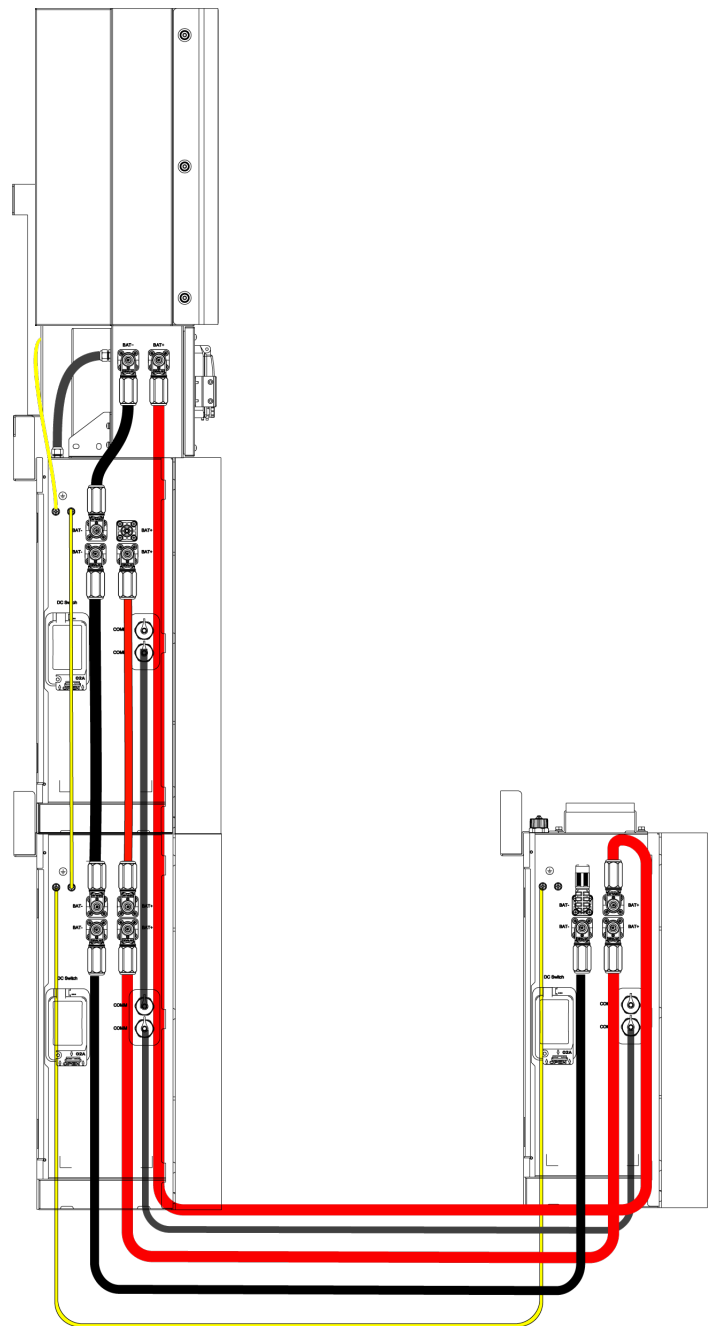

Cable Pack for 15.3kWh (3 Battery) System

Communication Cable

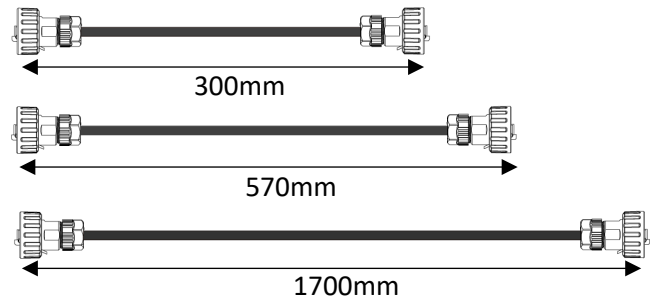

Power Cable – Negative (Black)

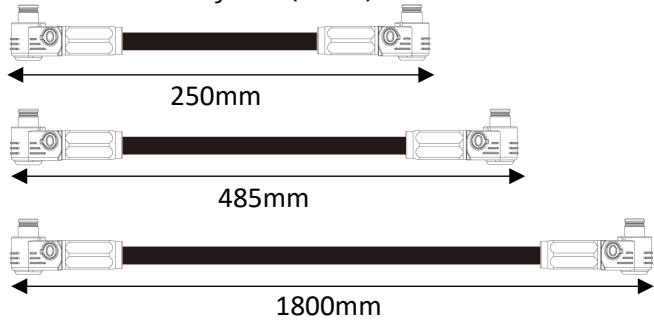

Power Cable – Positive (Red)

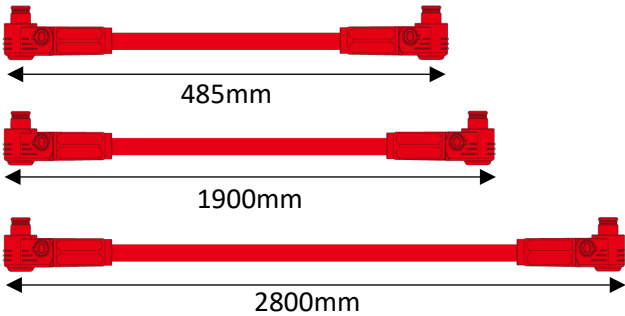

PE Cable

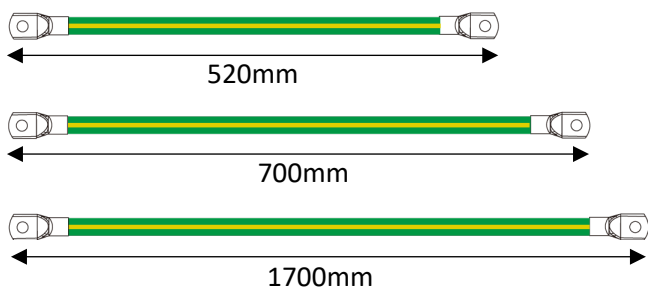

- Insert the black battery power cable (250mm) into the negative terminal on the left side of the inverter. Then, insert the other end into the top negative terminal on the left side of the battery.
- Insert the black battery power cable (485mm) into the bottom negative battery terminal of your first battery. Then, insert the other end into the top negative battery terminal of the second battery.
- Insert the black battery power cable (1800mm) into the bottom negative battery terminal of your second battery. Then, insert the other end into the top negative battery terminal of the third battery.
- Insert the red battery power cable (2800mm) into the positive terminal on the left side of the inverter. Then, insert the other end into the top positive terminal on the left side of the third battery.
- Insert the red battery power cable (1900mm) into the bottom positive battery terminal of the third battery. Then, insert the other end into the bottom positive battery terminal of the second battery.
- Insert the red battery power cable (485mm) into the top positive battery terminal of the second battery. Then, insert the other end into the bottom positive battery terminal of the first battery.
- Insert the grey/black communication cable (300mm) into the terminal on the back, left side of the inverter. Insert the other end into the communication terminal on the top of the first battery.
- Insert the grey/black communication cable (570mm) into the bottom COM terminal of the first battery. Then, insert

the other end into the top COM terminal of the second battery.

- Insert the grey/black communication cable (1700mm) into the bottom COM terminal of the second battery. Then, insert the other end into the bottom COM terminal of the third battery.
- Connect the PE Cable (700mm) to the earth connection on the back of the inverter, left side. Connect the other end to the earth connection on the left side of the top battery.
- Connect the PE cable (520mm) to the earth connection on the left side of the first battery. Then, connect the other end to the earth connection on the left side of the second battery.
- Connect the PE cable (1700mm) to the earth connection on the left side of the second battery. Then, connect the other end to the earth connection on the left side of the third battery.



Negative Battery Power Cable (Black), PE Cable and Communication Cable always go sequentially from inverter to first battery, to second battery and so on.

Positive Battery Power Cable (Red) has to have a reverse loop, this will always go from inverter to the last battery and work its way backwards.

20.4kWh (4 battery) System

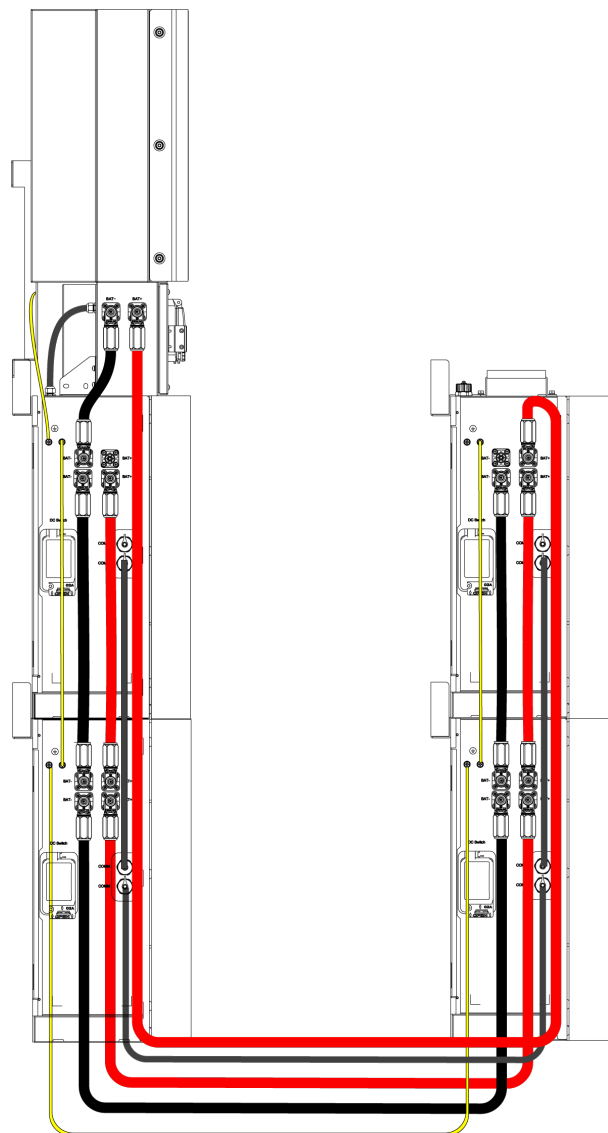

Cable Pack for 20.4kWh (4 Battery) System

Communication Cable

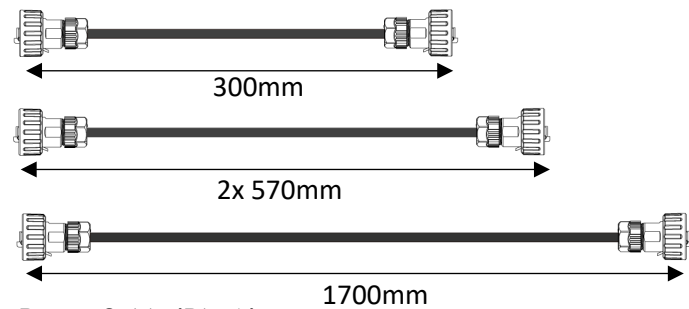

Power Cable (Black)

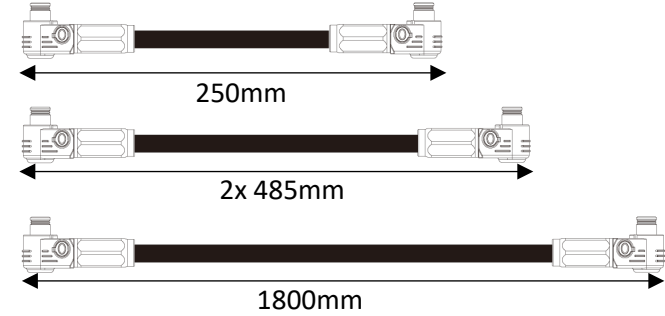

Power Cable (Red)

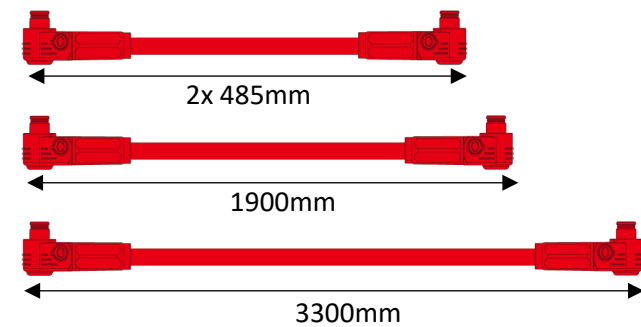

PE Cable

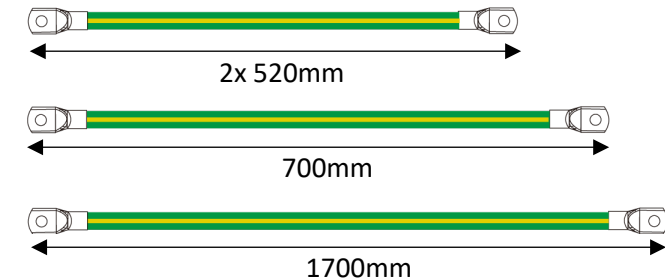

- Insert the black battery power cable (250mm) into the negative terminal on the left side of the inverter. Then, insert the other end into the top negative terminal on the left side of the battery.
- Insert the black battery power cable (485mm) into the bottom negative battery terminal of the first battery. Then, insert the other end into the top negative battery terminal of the second battery.
- Insert the black battery power cable (1800mm) into the bottom negative battery terminal of the second battery. Then, insert the other end into the top negative battery terminal of the third battery.
- Insert the black battery power cable (485mm) into the top negative battery terminal of the third battery. Then, insert the other end into the bottom negative battery terminal of the fourth battery.
- Insert the red battery power cable (3300mm) into the positive terminal on the left side of the inverter. Then, insert

the other end into the top positive terminal on the left side of the fourth battery.

- Insert the red battery power cable (485mm) into the bottom positive battery terminal of the fourth battery. Then, insert the other end into the top positive battery terminal of the third battery.
- Insert the red battery power cable (1900mm) into the bottom positive battery terminal of the third battery. Then, insert the other end into the bottom positive battery terminal of the second battery.
- Insert the red battery power cable (485mm) into the top positive battery terminal of the second battery. Then, insert the other end into the bottom positive battery terminal of the first battery.
- Insert the grey/black communication cable (300mm) into the terminal on the back, left side of the inverter. Insert the other end into the communication terminal on the top of the first battery.
- Insert the grey/black communication cable (570mm) into the bottom COM terminal of the first battery. Then, insert the other end into the top COM terminal of the second battery.
- Insert the grey/black communication cable (1700mm) into the bottom COM terminal of the second battery. Then, insert the other end into the bottom COM terminal of the third battery.
- Insert the grey/black communication cable (570mm) into the top COM terminal of the third battery. Then, insert the other end into the bottom COM terminal of the fourth battery.
- Connect the PE Cable (700mm) to the earth connection on the back of the inverter, left side. Connect the other end to the earth connection on the left side of the top battery.
- Connect the PE cable (520mm) to the earth connection on the left side of the first battery. Then, connect the other end to the earth connection on the left side of the second battery.
- Connect the PE cable (1700mm) to the earth connection on the left side of the second battery. Then, connect the other end to the earth connection on the left side of the third battery.
- Connect the PE cable (520mm) to the earth connection on the left side of the third battery. Then, connect the other end to the earth connection on the left side of the fourth battery.



Negative Battery Power Cable (Black), PE Cable and Communication Cable always go sequentially from inverter to first battery, to second battery and so on.

Positive Battery Power Cable (Red) has to have a reverse loop, this will always go from inverter to the last battery and work its way backwards.

- Close the panels on the sides of the battery(ies) tightening the screws to secure.
- Insert the RS45 cable into the 'COM' port on the right hand side of the inverter. You will connect the other end to the controller in the next section

6.2 Controller

WARNING

ELECTRIC SHOCK – An electric shock can be fatal; electrical connection work may only be carried out by a competent person.

6.2.1 Strip length

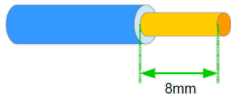

6.2.2 Supply

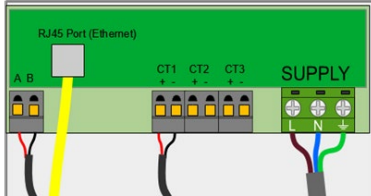

- Power to the controller must **NOT** be supplied by the backup.
- Adhere to local wiring regulations when selecting the type and size of cable to be used
- 3 Amp fuse recommended for fused mains supply
- When making mains connections it should be ensured that if the cable slips in such a way as to place strain on the conductors, the protective earthing conductor will be the last to take the strain

6.2.3 Gland Requirements

Glands are to be used as a way of anchoring the cables. The size of cable and gland used is the responsibility of the installer and should be determined on an install-by-install basis dependant upon install specifics.

6.2.4 Controller to Inverter Communication (RS485)

The controller communication cable, provided, must be inserted into the RS485 port of the controller, Red to A, Black to B.

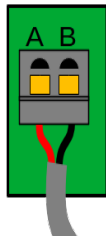

5m controller communication cable is supplied. If extension is required, it must be done using twisted pair cable like CAT5/6 and should **NOT** be extended further than the distance of 100m.

6.2.5 Ethernet Connection

If the intention is to connect the controller to the internet via a hardwired Ethernet connection, insert the Ethernet cable into the RJ45 port at this point.

If you will be connecting to the internet via WiFi leave this port empty.



If the controller detects an Ethernet connection it will turn off WiFi and default to a hardwired connection by default so it is important that if you intend to connect via WiFi to leave this port free.

6.2.6 CT Sensor Installation

Current Transformers (CTs) are used to measure current at various places of the installation. For example, the Grid connection point, the solar/wind inverter or a static battery system.

Installation of a CT to monitor the Grid connection point is required. Other CTs are optional and can be purchased separately. The number and location of CTs used within an installation will vary according to devices installed and the user requirements.

CTs can be wired to any myenergi device with CT inputs (e.g. libbi, eddi, zappi or harvi). This enables flexible installation as the CT can be wired to the nearest device.

The harvi device can be used for Generation CT, if it is not practical to connect any CT to the libbi.

Grid CT

The Grid CT sensor (supplied) needs to be clipped around either the Live or Neutral conductor of the electricity supply meter. If using the Neutral conductor, reverse the direction of the sensor (so the arrow is reversed).

The positioning of the Grid CT sensor is crucial, take note of the following when deciding where best to install the sensor:

- Can be connected to any myenergi device with a CT input e.g. the libbi, eddi or zappi (wired sensor) or harvi (wireless sensor)
- ALL of the imported and exported power must be 'seen' by the sensor – be sure to install it upstream of ANY junction box or 'Henley Block' (the CT can be fitted inside the consumer unit)
- There must be only one Grid CT per-phase for the whole installation
- The CT should be on the Live or Neutral cable
- The arrow on the bottom of the CT sensor must be pointing towards the consumer unit (in the direction of grid import) if on the Live cable, or reversed if on the Neutral cable
- Ensure the CT is fully closed and clicks shut
- Be sure to wire the CT the correct way round; black [-], red [+] otherwise import and export readings will be swapped

Additional CTs

There is an option to add other CT sensors (available separately) for monitoring the generation or other appliances, such as 3rd party battery systems. Installing a CT for the generator (PV system) will allow the main screen to show the generated power and the total power consumption of the all the other appliances in the property.

CTs can also be used to limit the power drawn from the supply:

- Additional CTs can be connected to any myenergi device with a CT input that is linked to the network
- The arrow on the bottom of the sensor must be pointing in the direction of normal power flow (e.g. away from the PV inverter) if on the Live cable or reversed if on the Neutral cable
- Ensure the sensor is fully closed and clicks shut
- Be sure to wire the CT the correct way round; black [-], red [+]

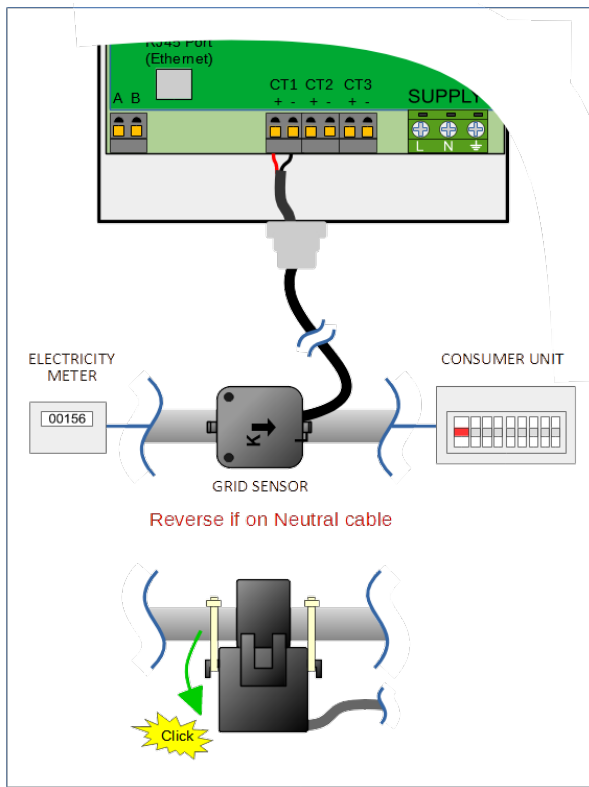

Extending CT Sensor Cable

If there is a need to extend the CT sensor cable, a twisted-pair cable like CAT5 or telephone cable must be used (only use one pair).

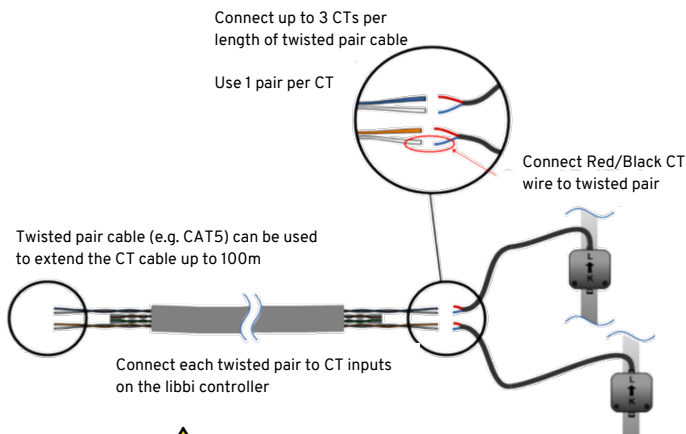

WARNING

Do NOT use mains cable, bell wire or speaker cable. It is important to use only twisted-pair cable to maintain signal integrity. The cable can be extended up to 100m.

CT Wireless Sensor (Optional Accessory)

In some cases it can be difficult or impractical to install a wired sensor. For example, it may be the case that the libbi unit needs to be connected to a sub-board, rather than main consumer unit and two consumer units are in different buildings.

The solution is to install harvi – a clever little device that enables myenergi products to be installed without using wired CT sensors for measuring the generation power; instead the CT sensor is connected to harvi.

The harvi does not need batteries or a power supply – the energy from the sensor is harvested and used to transmit the

measurement signal to the libbi. This means batteries or electrical wiring are eliminated!

Refer to the harvi installation guide for details on installing and configuring harvi for your system.

CT Golden Rules – Grid CT

- Only ONE Grid CT per phase (check for only one ~ symbol in Linked Devices Info)
- Located to 'see' ALL import and ALL export current (i.e. always upstream of any junction box)
- Arrow pointing in direction of import (e.g. towards consumer unit if on Live cable)

All other CTs

- Arrow should point towards the consumer unit

CT Can do's

- Can be wired to ANY myenergi device in the network
- Cable can be extended up to 100m (must use twisted-pair cable e.g. one pair of CAT5)
- Cable can be shortened
- Can be clipped around two or more conductors feeding appliances of the same type (e.g. two Live cables from two inverters that are on the same phase)
- Can be in close proximity to other CTs.
- Wires can be swapped around in device to reverse the direction of the readings (e.g. change import to export)
- Can be grouped with other CTs of the same type so that the power reading is summed (e.g. east and west solar Generation)
- Can be used on the Neutral conductor, on single phase installs, only (direction of arrow or wires must be reversed)
- Can be set to None if you want to exclude the reading

6.3 Fitting the Controller Cover

- 1) Place the cover back on, ensuring to align the top edge first.
- 2) Re-place and screw in the front cover Torx screw (1).

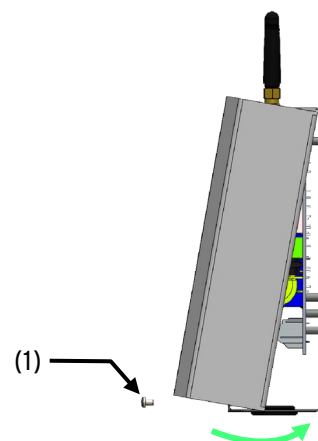

7. Wiring Overview Diagram

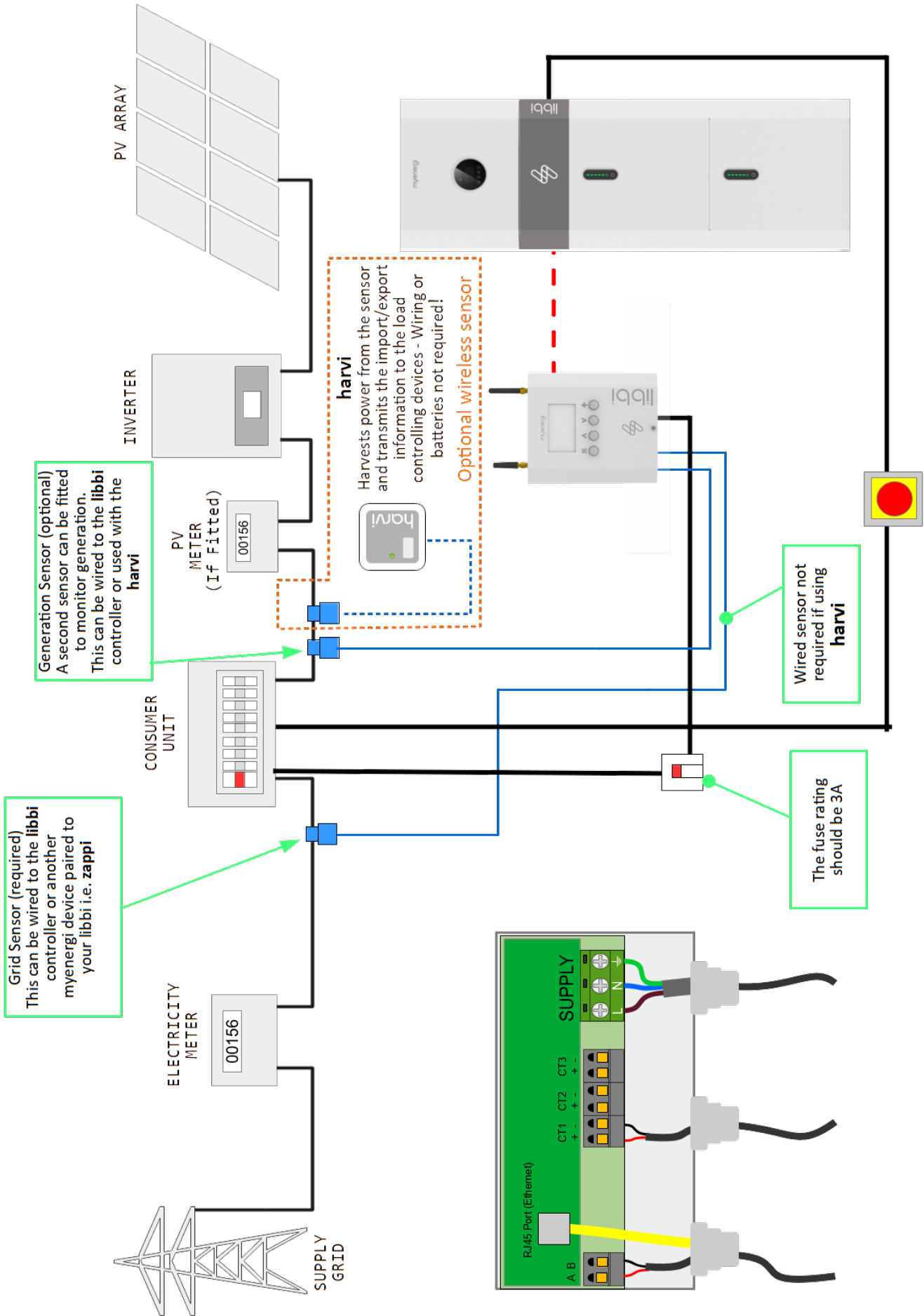

8. Initial Configuration

8.1 Power Up

8.1.1 Battery and Inverter



Please check the installation before switching on.



If PV is not present, skip the first step.

When turning the system on, it is very important to follow the steps below to prevent damage to the system.

You previously left the system with the front plate removed, after siting the battery and inverter at section 5.

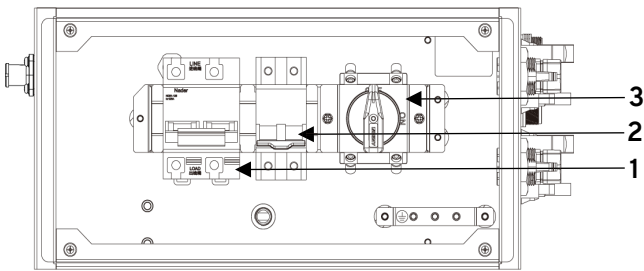

1. Battery Circuit Breaker
2. Backup Isolation Switch
3. DC Isolation Switch

- 1) Turn on the PV switch, if applicable.
- 2) Turn on AC Isolator.
- 3) Turn the backup/load isolation switch (if backup is connected).
- 4) Turn on battery switch.
- 5) Turn on all of the battery DC switches on the side of the battery module(s).
- 6) Press and hold the power button on any battery until the indicator light turns on (If you have more than one battery in the system, you only need to press the power button on one of them).
- 7) Close the battery switch cover and tighten the thumb screws to maintain IP rating. Then, replace cable box cover.

8.1.2 Controller

After completing and checking the wiring of the supply:

- 1) Switch on the libbi controller via the circuit breaker or fused spur.

8.2 Controller Set-up

When the libbi controller is first powered up, you will be presented with 'Setup Wizard' screens which prompt you to confirm the type of install you are undertaking. This helps to pre-configure the libbi, as required. To view a menu map of the setup wizard, refer to **Appendix C** at the back of this manual.

As part of the initial set-up the installer will be asked to set a passcode which will protect the settings in the installer menu from being changed.

8.3 CT Configuration

CT1 by default is set to GRID on every libbi. To amend the CT inputs connected to the libbi to match those installed, within the menu options navigate to:

Device settings > Installer > CT Config

CT CONFIG	
CTINT:	Internal Load
Type:	Single Phase
CT1:	Grid
CT2:	None
CT3:	None

Once in the CT config menu, use the up/down arrows to highlight the required CT input and press (+) to confirm. Within the CT Type, adjust as required by pressing (+) and then the up/down arrows to choose, pressing (+) again to confirm when finished.

It is possible to monitor a 3-phase supply directly on the libbi by Selecting '3 Phase' as the 'Type'. This will automatically change all 3 CT inputs to 'Grid'

8.4 Pairing Devices

8.3.1 Overview

If libbi is being installed as a standalone myenergi device you can skip this section.

Up to 6 myenergi devices can be wirelessly linked together. The device you are using as your 'hub' will count as 2 of the 6 devices. By pairing devices, you can use more of your own energy or have more control and visibility. Devices available are:

eddi A microgeneration energy diverter that uses surplus energy to heat water or rooms rather than exporting to the grid.

zappi An eco-smart electric vehicle charge point that can use surplus energy to charge the car.

harvi A self-powered wireless sensor that can be used along with myenergi load controlling devices such as libbi, eddi and zappi. It is able to detect grid import/export conditions as well as generation energy and send this information wirelessly to devices. Using a harvi can greatly simplify installation.

myenergi devices can be linked using either the built-in radio or with an Ethernet cable. If using an Ethernet connection **the libbi controller** simply needs to be connected to your local network – either with an Ethernet cable running directly to your internet router or via built-in WiFi.

8.3.2 Master & Slave Devices

When two or more **myenergi** devices are wirelessly linked, one device will act as the *master* device. This device will control the other *slave* devices. Some settings can only be changed on the master device.

Your master/slave on your new device will be set during start-up however, if this ever needs to be changed you can set Master function in the Installer Settings/Linked Devices menu. It's a good idea to choose the device that is the most convenient to access should you wish to change settings.

- harvi will only pair with the device which is set as the master
- It is recommended that, where the Grid CT is directly connected to the eddi, that this device is chosen as the master or vice versa. This ensures the fastest response to the grid power measurement

8.3.3 Channels

Devices will usually use Radio Frequency (RF) Channel 1. It is important that all myenergi devices are using the same channel. On rare occasions, it is possible that there are other appliances operating on the same frequency which could cause interference. If it is not possible to link devices or the connection seems poor, changing the RF Channel may help.

8.3.4 Pairing libbi

When installing libbi into an existing myenergi eco-system, then libbi will be linked as a 'slave' to the existing 'master'. libbi has already been set as 'slave' from the answers you gave during the setup wizard.

- 1) Go to your 'master' device and in the device menu navigate to: "Device Settings" > "Installer Settings" > "Linked Devices" > "Pairing Mode".

Your "Master" will begin searching for "Slave" devices.

- 2) Go to your libbi controller menu and navigate to:

"Device Settings" > "Installer Settings" > "Linked Devices" > "Pairing Mode"

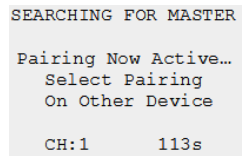

- 3) When you see your libbi device display on your 'master' device screen, select (+) on your master device to confirm.

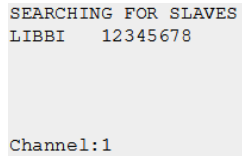

8.5 Device Settings

Most device types have settings which can only be changed via the Linked Devices menu. For example, libbi, eddi and zappi have a setting for priority and harvi has settings to configure its CT inputs.

The device settings are accessed through the Linked Devices menu; select Devices then select the appropriate device and press (+) to bring up the device settings screen. Refer to the relevant device instruction document for more information regarding the actual device settings.

After a device has been paired you will have to wait a few seconds for the device to update before the settings can be accessed. The screen will show DEVICES UPDATING when this is happening.

8.4.1 Device Priorities

The priority of each, load controlling linked device, can be set from any device with a display. The example below shows one eddi device, two zappi devices and one harvi on the same 'network'. If you have a myenergi libbi, this will be shown in your Devices list.

	DEVICES			
1 →	1	eddi...	12345678~	← 3
	2	zappi...	24680246	
	2	zappi...	03699630	← 4
2 →	3	LIBBI	23456789	
		harvi	12432678?	← 5

- 1 The priority is shown on the left of each load controlling device with 1 being the highest priority. If two or more devices have equal priority, the available surplus (for that priority level) is shared between them.
- 2 The device shown in CAPITAL letters is the device currently being viewed.
- 3 The ~ symbol indicates which device has the grid CT attached /configured to it. There should only be one in the system.
- 4 The serial number of each device is shown on the right.
- 5 If the ? symbol is shown alongside a device, it indicates that communication has been lost from the device (the device cannot be 'heard')

8.4.2 Removing Devices

A device can be removed by navigating to: "Installer Settings" > "Linked Devices" > "Device menu" and then select Remove Device.

If you want to remove ALL devices then go to:

"Installer Settings" > "Linked Devices" > "Reset Settings"

8.6 Internet Connectivity

8.5.1 Internet Connection – Hardwired Ethernet

If connecting to the internet via WiFi, skip ahead to the next section.

If connection to the internet is being made by hardwired Ethernet you will have already inserted the Ethernet cable into the RJ45 Port of the controller during section 6.1 of these instructions.

Simply connect the other end of the cable into the customer's home router and connection to the internet will occur.



If the device detects an Ethernet connection it will use this and turn off WiFi options within the device. If at any time the Ethernet cable is removed, it will not automatically turn WiFi options back on. These will need to be turned on manually within the device menu.

8.5.2 Internet Connection – WiFi

- 1) Go to the main menu on your libbi controller and navigate to: 'Device Settings' > 'Internet' > 'WiFi'

```
WIFI SETUP
Connect to the
hotspot below to
setup
SSID: myenergi XXXX
P/W: a8jdl0qHB4p
Status: Disconnected
Press X to skip
```



Make a note of the SSID and Password (P/W) now for use in the following steps.

- 2) Connect your smartphone or computer to the myenergi access point by entering your phone or computer WiFi Settings and searching for the network displayed with the same name as the SSID you noted down above. Once displayed, select the network to connect.

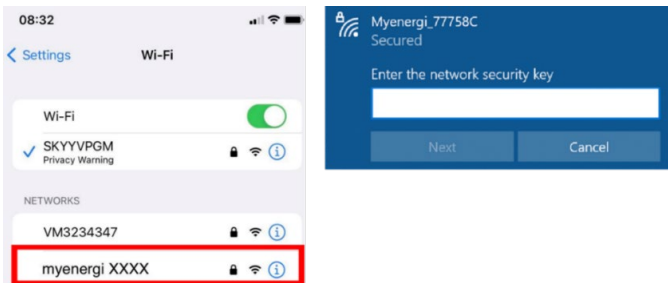

- 3) You will be prompted for a password. Enter the password displayed on the libbi controller screen that you noted down at step 7.
- 4) You will now be prompted to create a new password to protect the WiFi settings from being changed by anyone else. The new password must be at least 8 characters long and consist of a combination of lowercase and uppercase letters and digits.
- 5) Wait 5 seconds for your password to change and the webpage to reload.

- 6) Once connected, you will be directed to another webpage where you will need to select your home WiFi network from the list in the "Detected Networks" box and type in your home WiFi's password to connect to your router.



However, if you want to give your libbi a fixed IP address then tick the "Show IP Settings" box and fill in the extra information required.



If page doesn't load, type 192.168.4.1 into your web browser or mobile phone browser to enter WiFi setup screen.



Please be patient. It could take up to 15 seconds for the connection to take place.

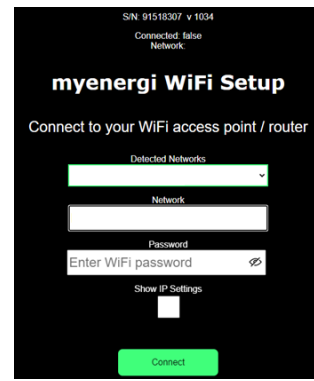

8.7 Export Limitation

With a growing number of renewable generation (such as PV and Wind Turbines) in homes and businesses, there is the risk that the grid could be overloaded if there are large amounts of surplus generation being exported all at once. To avoid this issue, Distribution Network Operators (DNOs) stipulate a pre-determined amount of electricity that can be exported to the grid. This is the 'export limit' which may vary per property. With export limitation present within libbi, the DNO doesn't have to worry about large amounts of surplus electricity entering the grid.

Under normal operating conditions myenergi devices will aim to use all available surplus energy within the property before exporting anything back to the grid. However, a limit to export may be necessary, and libbi allows you to set a limit reflective of the amount stipulated by the DNO.

To do this, in the libbi controller menu, navigate to:

'Main Menu' > 'Device Settings' > 'Installer' > 'Supply Grid' > 'Export' > 'Export Limit'

The 'Export Limit' may be set to an amount between 1 – 100A or 'off'. If set to 'off' this will automatically set the device to its maximum capacity. Depending on the requirement of the DNO, set the limit accordingly. If you are working in kW, you can convert this to Amps working on the basis that 1kW = 4.35Amp.

Example 1 – libbi is the only device with potential of exporting to the grid

In this scenario there is a libbi only. Export Limit in the libbi controller device menu has been set to 16A. The PV is currently generating 3kW of energy. As the libbi battery is full, it cannot store any of the generated energy and the property doesn't require any load at this time, leaving it as surplus. The DNO, in this example, have stated maximum export allowed to the grid is 3.68kW. The libbi will therefore allow the 3kW of the surplus energy to leave the inverter and be exported to the grid.

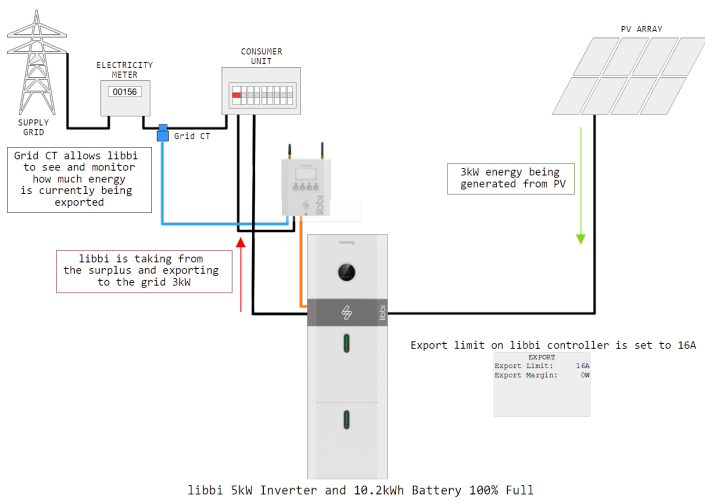

met. libbi takes the 0.6kW available from PV Array 2 and exports this to the grid.

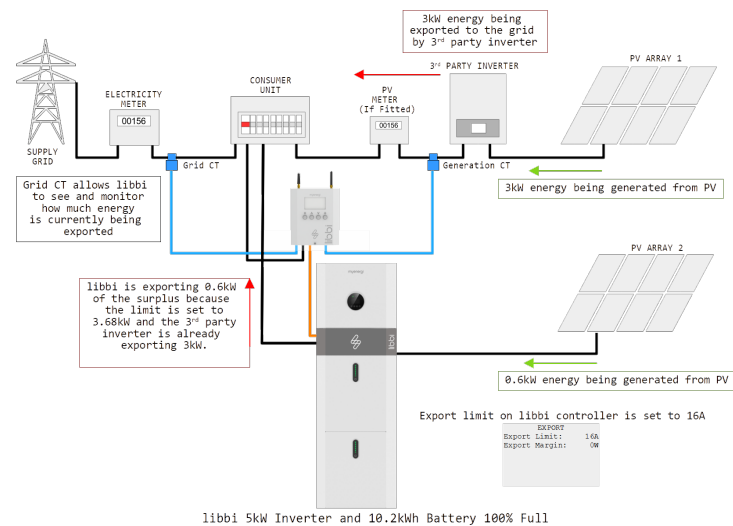

Example 2 – There is more than one device with potential to export to the grid and export limit has been reached

In this scenario there is a libbi and a 3rd party inverter. There are two PV arrays, the first with a 3rd party inverter and the second directly connected to libbi. Export Limit in the libbi controller device menu has been set to 16A. The PV is currently generating 5kW energy from PV Array 1, with another 2kW potential generation from PV Array 2. As the libbi is full, it cannot store any of the generated energy and the property doesn't require any load at this time, leaving it as surplus. The DNO, in this example, have stated maximum export allowed to the grid is 3.68kW. The 3rd party inverter is already taking 5kW of the surplus and exporting this straight back out to the grid. libbi is constantly monitoring the grid CT and knows that the limit has already been exceeded. In this case the libbi will stop itself exporting any generation from PV Array 2. Status will show on the controller screen as "Export Limited".

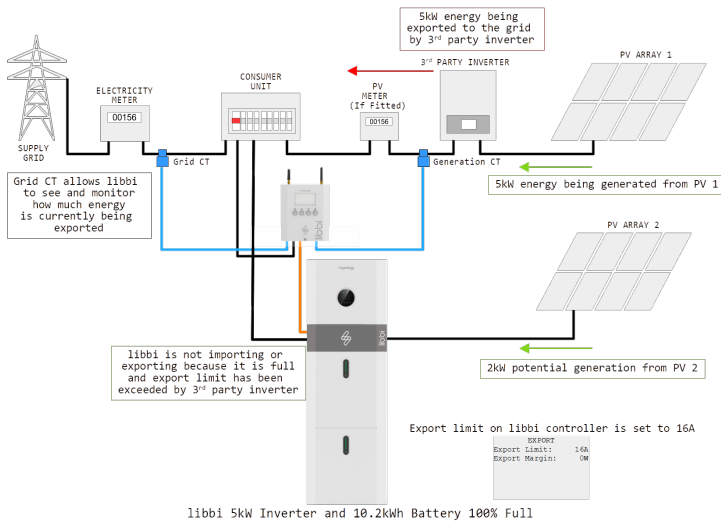

Example 3 – There is more than one device with potential to export to the grid and export limit hasn't been reached

In this scenario there is a libbi and a 3rd party inverter. Export Limit in the libbi controller device menu has been set to 16A. PV Array 1 is currently generating 3kW energy and PV Array 2 is currently generating 0.6kW. As the libbi is full, it cannot store any of the generated energy and the property doesn't require any load at this time, leaving it as surplus. The DNO, in this example, have stated maximum export allowed to the grid is 3.68kW. The 3rd party inverter is taking 3kW of surplus from PV Array 1 and exporting this straight back out to the grid. libbi is constantly monitoring the grid CT and knows that the limit has not yet been

8.8 Grid Limit

When installing a libbi the GRID limit must be set. This is to ensure our load balancing feature will protect the main fuse of the property when importing from the GRID.

To do this, in the menus navigate to:

“Device settings” > “Installer Settings” > “Supply Grid” > “Network” > “Grid Limit”

NETWORK	
Grid Limit:	Off
Ext Bat:	None
Net Phases:	Off
Neutral Limit:	Off
Power Limit:	off

It is set to 'OFF' as default and needs to be adjusted accordingly.

9. Product Registration (Installer Portal)

It is the installers responsibility to ensure each libbi installed is registered in the myenergi installer portal. Registration of the libbi within the installer portal commences the Product Warranty.

Following certified myenergi libbi training, each installer will have an account set up and be given log in details.

The installer portal can be found at installer.myenergi.com which can be accessed on your mobile browser.

Each product will need to be entered individually and the barcode required can be found on the packaging of each product.

Once entered, the products will become visible in your customers myenergi myaccount.



The first time you log in you will be asked to change your password.



Barcode required for EACH battery installed (up to 4). Press the “Add Battery” button to create another entry field. Barcodes can be entered manually, if necessary.

1) You will receive an account log on after completing the myenergi libbi installation training.

Go to installer.myenergi.com and enter your login details.

- 2) For each libbi install, scan the barcode on the battery, inverter and controller
- 3) Once details for inverter, controller and battery(ies) have been entered, press “Submit”.

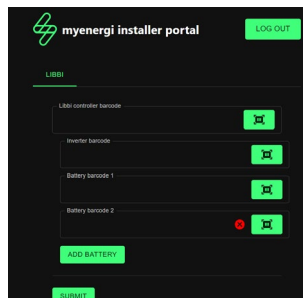

10. Product Registration (Customer app and myaccount)

Before you leave the customer please ensure they have registered their new device in the myenergi app and myaccount.

If this is the customer’s first myenergi device please follow the “First myenergi Device” instructions below. If this is an additional device and the customer already have a myenergi account follow “Additional device installed” instructions.

First myenergi device

If this is the customer’s first myenergi device they will need to register for an account.

- 1) Download the myenergi app on the customers phone or tablet device.
- 2) Open the app and click, “Register for an account”.
- 3) Enter the customer’s email address and have the customer create a password, when prompted.
- 4) Select the customer’s preferred contact preferences, then click “next”.
- 5) Have the customer check their email for a verification code.
- 6) Enter the verification code into the app, where requested and press “next”.
- 7) In the app, click the green “+” symbol to add the customer’s first location.
- 8) When asked if there is a ‘hub’ present, select “No”, as this is the customer’s first myenergi device and will already have a built-in virtual hub (vHub).
- 9) Enter the “Reg S/N” and “Reg Code”



These can be found in the libbi controller menu settings:
Menu > Information > Page 2

- 10) Once complete your device will now show in the customers myenergi app and myaccount.

Before you leave, inform the customer that they need to visit myaccount.myenergi.com from a web browser at their earliest convenience and finish setting up their account.

Additional device installed

If libbi has been installed into an existing myenergi eco-system the customer should already have an account set up.

Once the libbi is paired with the existing, registered myenergi device(s) the libbi should automatically appear as a device in the customer’s myenergi app and myaccount.

Check this has happened before you leave.

11. Commissioning

To ensure the libbi install has been successful and is fully compliant with any local regulations, there are certain elements to be tested and confirmed before leaving site.

- Check all battery modules are connected and communicating. To do this in the controller device menu navigate to: **Main Menu > Readings > Readings 5/6**

This screen is showing a 10.2kWh system with a 5kW inverter. If the battery size isn’t showing all modules installed check comms cables between batteries are inserted correctly, then reboot the system and check this readings screen again.

READINGS 5/6	
Battery Size:	10200Wh
Inverter Rating:	5000W
SoC:	59.0%
Charge:	3009Wh
Rate:	1%

- Complete “Basic Functional Testing”. This is required in order to comply with G98 & G99
- Check the time and date are correct. This is crucial for supporting any tariff schedules that have been set
- Check the grid power CT is showing sensible readings and the direction of the power flow is as expected
- If generation CT has been installed, check that the generated power is shown in the top left of the main controller display (If PV is connected directly to the libbi inverter, separate generation CT is not required)
- Check that libbi is connected to the internet and is working correctly. This also ensures the “update from cloud” option is automatically enabled
- Make sure any required safety limits have been set i.e. Grid limit
- Confirm the backup is working as expected
- Ensure all module elements, including controller, are registered.
- Ensure the customer is happy with the app settings and they know how to use it.

12. Routine Maintenance & Cleaning

We *recommend* a routine observation of the libbi every 6 months. This should be carried out by a competent person and its main aim is to look for any signs of damage and abnormalities. This is a visual inspection only and should not entail removing the cable box cover or dismantling the libbi in any way.

A full maintenance inspection is *recommended* to be carried out by a **qualified person** every 6-12 months. This is to check cables and terminals.

Observational Inspection (Every 6 months)

Operating Environment

- By sight only, carefully observe whether there are any signs of damage to the libbi
- Listen to any part of the system for any abnormal noises
- Check whether the voltage, temperature and other parameters of the battery and other equipment parameters are normal during system operation.

Equipment Cleaning

- Ensure the ground is clean and tidy
- Keep the maintenance access route unblocked
- Ensure warning signs are clear and intact

- Monitor the temperature of the battery module
- Clean the battery module enclosure, if necessary

Full Maintenance Inspection (Every 6-12 months)

Cable, Terminal and Equipment Inspection

- Check for loose cable connections
- Check for aging and/or damaged cables
- Check for loosening of the cable terminal screws
- Check for any signs of overheating
- Check the earthing is still present and meets local wiring regulations

WARNING

ELECTRIC SHOCK – An electric shock can be fatal; electrical connection work may only be carried out by a competent person.

READ THE BELOW INSTRUCTIONS

- Related safety standards and specifications should be followed for operation and maintenance
- Ensure all electrical connections are disconnected and cannot be powered on before removing any covers
- Wait at least 5 minutes after disconnection to allow residual voltage of the capacitors to drop to a safe voltage. Use a multimeter to check the equipment has fully discharged
- Appropriate Personal Protective Equipment should be worn whilst maintaining the libbi

12.1 Emergency Power Down Procedure

If you are ever advised by myenergi Tech Support or by the fault code instruction to power down the libbi, follow the below procedure to do this safely.

- 1) Open the cable box cover. Unscrew the two thumb screws to access the switch box.
- 2) Turn off the battery switch.
- 3) Turn off the switch on side of battery or all batteries if the system has more than one.
- 4) Press and hold ALL power buttons on front of the battery or batteries.
- 5) Turn off the backup/load isolation switch/breaker (if backup is connected).
- 6) Turn off AC Isolator.
- 7) Turn off the PV switch, if applicable.

12.2 Battery Reboot

- 1) Open the cable box cover. Unscrew the two thumb screws to access the switch box.
- 2) Turn off battery switch.
- 3) Turn off the switch on side of battery or all batteries if the system has more than one.
- 4) Press and hold ALL power button on batteries.
- 5) Leave for 30 seconds.
- 6) Turn on the switch on the side of battery, or all batteries if the system has more than one.
- 7) Turn on the battery switch in the wiring box.
- 8) If issues persist, contact myenergi Tech Support.

13. Warranty

Full details of the myenergi product warranty are available on our website or by using this QR code.



<https://www.myenergi.com/terms-and-conditions/myenergi-product-warranty/>

Installer Portal

As part of the install, you, as the approved installer, are required to input the serial numbers of the inverter, battery(ies) and controller into the myenergi Installer Portal. This allows us to know when the customer's Warranty period begins.

If at any point in the future, the customer decides to upgrade their system by adding an extra battery, this will allow us to know when the Warranty period begins for the part added at a later date.

14. Help Centre

If you experience any issues with your myenergi device, please visit our Help Centre by scanning the QR Code or clicking the link below.

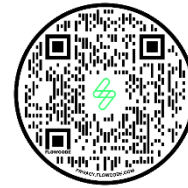

<https://support.myenergi.com/hc/en-gb>

14.1 Status, Warning and Fault Codes

Code 51: Max Charge Grid Limit

Status only - The battery's charge rate is being limited by the grid limit or grid limit is exceeded whilst libbi is in stop mode.

Code 52: Max Drain Grid Limit

Status only - The battery's drain rate is being limited by the grid limit.

Code 53: Max Charge Device Limit

Status only - The battery's charge rate is being limited by the device limit.

Code 54: Max Drain Device Limit

Status only - The battery's drain rate is being limited by the device limit.

Code 55: Max Charge Group Limit

Status only - The battery's charge rate is being limited by a group limit. Shows whilst in stop mode too.

Code 56: Max Drain Grid Limit

Status only - The battery's drain rate is being limited by a group limit.

Code 57: Harvi Lost Comms

Harvi has not been heard from for 24 hour+.

- 1) Check harvi is on.

- 2) Re-pair myenergi devices.
- 3) Contact myenergi Tech Support.

Code 58: Generation CT Polarity

Polarity of the gen CT is the wrong way around.

- 1) Correct the install by correcting the polarity of the generation CT.
- 2) If problem persists contact myenergi Tech Support.

Code 101: Battery Empty

Status only - The minimum state of charge has been met.

Code 102: Battery Full

Status only - The maximum state of charge has been met

Code 106: Grid CT Lost

Grid readings have been lost, device has stopped to be safe.

- 1) Check grid CT is connected to the controller.
- 2) If problem persists, contact myenergi Tech Support.

Code 107: Master Lost

Load control device has been lost, device has stopped to be safe.

- 1) Ensure master device is powered on.
- 2) Check pairing of all devices and re-pair, if necessary.
- 3) Check all device are on the same channel.
- 4) If issue cannot be resolved, call myenergi Tech Support.

Code 151: Inverter Undervoltage

The inverter reports low grid voltage.

- 1) Check inverter is connected to the grid.
- 2) If issue persists, contact myenergi Tech Support.

Code 152: Inverter Overvoltage

The inverter reports high grid voltage.

- 1) Contact myenergi Tech Support.

Code 153: Inverter Under Frequency

The inverter reports low grid frequency.

- 1) Contact myenergi Tech Support.

Code 154: Inverter Over Frequency

The inverter reports high grid frequency.

- 1) Contact myenergi Tech Support

Code 156: Battery Lost

Communications between the battery and inverter have failed.

- 1) Check battery is turned on.
- 2) Check battery power cables and battery comms cables are connected.
- 3) Contact myenergi Tech Support

Code 157: Battery Undervoltage

Battery voltage is under threshold.

- 1) Reboot Battery.
- 2) If issue persists, contact myenergi Tech Support.

Code 158: Battery Voltage Low

Reporting low battery voltage.

- 1) Reboot battery.
- 2) If issue persists, contact myenergi Tech Support.

Code 159: Battery Voltage High

Reporting high battery voltage.

- 1) Reboot battery.
- 2) If issue persists, contact myenergi Tech Support.

Code 160: Overload

Inverter circuit overloaded. Occurs when the demand is more than the inverter can deliver, when in backup mode.

- 1) Turn off loads powered by the backup circuit.
- 2) If problem persists, contact myenergi Tech Support

Code 161: GFCI Over Threshold

Inverter internal protection triggered due to internal fault in inverter.

- 1) Contact myenergi Tech Support

Code 163: Fan Fault

Inverter fan fault detected.

- 1) Contact myenergi Tech Support.

Code 164: Bat Under Capacity

Battery power is insufficient to discharge.

- 1) Contact myenergi Tech Support.

Code 165: BMS Discharge Over Current

- 1) Reboot battery.
- 2) If issue persists, contact myenergi Tech Support.

Code 166: BMS Charge Over Current

- 1) Reboot battery.
- 2) If issue persists, contact myenergi Tech Support.

Code 167: BMS Over Voltage

- 1) Reboot battery.
- 2) If issue persists, contact myenergi Tech Support.

Code 168: BMS Over Temperature

- 1) Check ambient temperature at install site.
- 2) Contact myenergi Tech Support.

Code 169: BMS Discharge Temperature Low

- 1) Check ambient temperature at install site.
- 2) Contact myenergi Tech Support.

Code 170: Battery Voltage Imbalance

- 1) Reboot battery.
- 2) If issue persists, contact myenergi Tech Support.

Code 171: BMS Communications Fault

- 1) Reboot battery.
- 2) Check communication cable and battery/inverter power cables are connected.
- 3) If issue persists call Tech Support.

Code 172: BMS Under Voltage

- 1) Reboot battery.
- 2) Check battery/inverter power cables are connected.
- 3) If issue persists, contact myenergi Tech Support.

Code 173: BMS Charge Temperature Low

- 1) Check ambient temperature at install site.
- 2) Contact Tech Support.

Code 174: BMS Voltage High

- 1) Reboot battery.
- 2) If issue persists, contact myenergi Tech Support.

Code 175: BMS Temperature High

- 1) Check ambient temperature at install site.
- 2) Contact myenergi Tech Support.

Code 179: Grid CT Polarity

Grid CT may be the wrong way around.

- 1) Check CT installation and correct, if necessary.
- 2) If issue persists, contact myenergi Tech Support.

Code 183: Inv Comms Lost

- 1) Check inverter and controller are turned on.
- 2) Check RS485 cable is connected to inverter.
- 3) Check polarity of the RS485 cable is correct at controller end.
- 4) Check integrity of the cable.
- 5) If problem persists contact myenergi Tech Support

Code 184: Controller Undervoltage

- 1) Contact DNO (Distributed Network Operator).
- 2) If issue persists, contact myenergi Tech Support.

Code 185: Controller Overvoltage

- 1) Contact DNO (Distributed Network Operator).
- 2) If issue persists, contact myenergi Tech Support.

Code 186: Controller Under Frequency

- 1) Contact DNO (Distributed Network Operator).
- 2) If issue persists, contact myenergi Tech Support.

Code 187: Controller Over Frequency

- 1) Contact DNO (Distributed Network Operator).
- 2) If issue persists, contact myenergi Tech Support.

Code 201: Soft Timeout

- 1) Power down following the power down procedure.
- 2) If issue persists, contact myenergi Tech Support.

Code 202: Internal Voltage Short

- 1) Power down following the power down procedure.
- 2) If issue persists, contact myenergi Tech Support.

Code 203: GFCI Sensor Fault

- 1) Power down following the power down procedure.
- 2) If issue persists, contact myenergi Tech Support.

Code 205: Bus Low Fault

- 1) Power down following the power down procedure.
- 2) If issue persists, contact myenergi Tech Support.

Code 206: Bus High Fault

- 1) Power down following the power down procedure.
- 2) If issue persists, contact myenergi Tech Support.

Code 207: Bus Short Fault

- 1) Power down following the power down procedure.
- 2) If issue persists, contact myenergi Tech Support.

Code 208: PV ISO Under

- 1) Power down following the power down procedure.
- 2) Check earth resistance of PV.
- 3) Check for good earthing installation.
- 4) If issue persists, contact myenergi Tech Support.

Code 209: PV Input Short Circuit

- 1) Disconnect PV safely using the DC isolator.
- 2) Power down following the power down procedure.
- 3) Reconnect PV.

- 4) Check PV and wiring against any short circuit.
- 5) If issue persists, contact myenergi Tech Support.

Code 210: Bypass Relay Fault

- 1) Disconnect PV safely using the DC isolator.
- 2) Power down following the power down procedure.
- 3) Reconnect PV.
- 4) Check PV and wiring against any short circuit.
- 5) If issue persists, contact myenergi Tech Support.

Code 211: Inverter Overcurrent

- 1) Wait 5 minutes for inverter to restart.
- 2) If issue persists, power down following the power down procedure.
- 3) Check all wiring, including back up circuit.
- 4) If problem still persists contact myenergi Tech Support.

Code 212: Inverter DC Over

- 1) Power down following the power down procedure.
- 2) If issue persists, contact myenergi Tech Support

Code 213: Ambient Over Temperature

- 1) Check ambient temperature at install site.
- 2) Power down following the power down procedure.
- 3) Power up libbi following the power up procedure.
- 4) If problem persists, contact myenergi Tech Support.

Code 214: Sink Over Temperature

- 1) Check ambient temperature at install site.
- 2) Power down following the power down procedure.
- 3) Power up libbi following the power up procedure.
- 4) If problem persists, contact myenergi Tech Support.

Code 215: Grid Relay Fault

- 1) Disconnect PV safely using the DC isolator.
- 2) Power down following the power down procedure.
- 3) Power up libbi following the power up procedure.
- 4) Reconnect PV.
- 5) Check mains wiring.
- 6) If issue persists, contact myenergi Tech Support.

Code 216: Discharge Overcurrent

- 1) Wait 1 minute for inverter to restart.
- 2) Power down following the power down procedure.
- 3) Power up libbi following the power up procedure.
- 4) If problem persists, contact myenergi Tech Support.

Code 217: Charge Overcurrent

- 1) Check battery wiring port is short circuited.
- 2) If issue persists, contact myenergi Tech Support.

Code 219: Inverter Abnormal

- 1) Power down following the power down procedure.
- 2) Power up libbi following the power up procedure.
- 3) If issue persists, contact myenergi Tech Support.

Code 220: EPS Relay Fault

- 1) Disconnect PV safely using the DC isolator.
- 2) Power down following the power down procedure.
- 3) Power up libbi following the power up procedure.
- 4) Reconnect PV.
- 5) Check backup circuit wiring.
- 6) If issue persists, contact myenergi Tech Support.

Code 232: SCI Fault

- 1) Power down following the power down procedure.
- 2) Power up libbi following the power up procedure.
- 3) If issue persists, contact myenergi Tech Support.

Code 251: Upgrading DSP

Status only - DSP upgrade on inverter has started - Will clear when upgrade is complete.

Code 252: Upgrading ARM

Status only - ARM upgrade on inverter has started - Will clear when upgrade is complete.

15. Specifications

Battery Specification

Electrical		BMS	
Energy Capacity:	5.12kWh	Max. Short Circuit Current:	125A
Useable Capacity:	4.6kWh	Capacity:	100 – 400Ah
Nominal Voltage:	51.2V	Power Consumption:	<2W
Depth of Discharge:	90%	Operating Voltage Range:	44.8 – 56.5V
		Modules Connection:	Max. 4 batteries in parallel
		Internal Resistance:	<20mΩ
		Monitoring Parameters:	System voltage, current, cell voltage, cell temperature, PCBA temperature measurement
		Cycle Life:	Unlimited*
Operation		Physical	
Max. Charge/Discharge Current:	50A/80A	Storage Temperature Range:	-20°C to +50°C
Operating Temperature Range:	-10°C to +50°C	Battery Type:	LFP (LiFeP04)
		Humidity:	0 – 95%
		Weight:	54kg
		Dimension (WxHxD):	540 x 490 x 240mm
		IP Protection:	IP65
Compliance			
IEC 62040-1, IEC 62619, IEC 63056 & UN38.3. IEC/EN61000-6-1, IEC/EN61000-6-2, EN61000-6-3 & IEC/EN61000-6-4.			

Inverter Specification

Inverter General	3.68kW Inverter	5kW Inverter	AC Output	3.68kW Inverter	5kW Inverter
Max. PV Power (Per MPPT String):	2400W	3750W ²	Nominal AC Output Power:	3680W	5000W
Max. DC Voltage:	580V		Max. AC Output Power:	3680W	5000W
Nominal Voltage:	400V		Max. Output Current:	16A	22A
MPPT Voltage Range:	80V – 560V		Max. AC Apparent Power:	7360VA (from grid)	
Start Voltage:	150V		Nominal AC Voltage:	230Vac	
Number of MPP Tracker:	2		AC Grid Frequency Range:	50 / 60Hz +/-5Hz	
Strings Per MPP Tracker:	1		Max. Input Current:	32A	
Max. Input Current MPPT:	15A/15A		Power Factor (cosΦ):	0.8 leading – 0.8 lagging	
Max. Short-Circuit MPPT:	18A/18A		THDi:	<3%	
Battery Input	3.68kW Inverter	5kW Inverter	AC Output (Backup)	3.68kW Inverter	5kW Inverter
Max. Charging Current:	50A	100A	Max. Output Apparent Power:	4000VA	5000VA
Max. Discharging Current:	80A	100A	Max. Output Current:	16A	20A
Max. Charge/Discharge Power: (1 battery module)	2825/4000W	2825/4096W	Peak Output Apparent Power:	6900VA 10sec	
Max. Charge/Discharge Power: (2-4 battery modules)	3000/4000W	4600/5000W			
Battery Type:	LFP (LiFeP04)		Nominal Output Voltage:	230V	
Nominal Battery Voltage:	48V		Nominal Output Frequency:	50 / 60Hz	
Charging Voltage Range:	40-60V		Output THDv (@Linear Load):	<3% (Linear Load)	
Battery Capacity:	100 – 400Ah				
Charging Strategy For Li-Ion Battery:	Depends on the BMS				
Efficiency	3.68kW Inverter	5kW Inverter	Protection	3.68kW Inverter	5kW Inverter
Max. PV Efficiency:	97.6%		DC Switch:	Bipolar DC Switch (125A/Pole)	
Euro PV Efficiency:	97.0%		AC/DC Surge Protection:	DC Type II, AC Type III	
			DC Reverse Polarity Protection:	Yes	
			Output Over Current Protection:	Yes	
General Specification	3.68kW Inverter	5kW Inverter	Anti-islanding Protection:	Yes	
Dimensions W x H x D:	540 x 590 x 240mm		String Fault Detection:	Yes	
Weight:	32kg		Insulation Detection:	Yes	
Operating Temperature:	-25 to +60°C derating above 45°C		AC Short Circuit Protection:	Yes	
Noise:	<25dB				
Cooling Type:	Natural Convection				
Max. Operation Altitude:	2000m		Compliance	IEC/EN62109-1/2; IEC/EN61000-6-1; IEC/EN61000-6-2; EN61000-6-3; IEC/EN61000-6-4.	
Max. Operation Humidity:	0-95% (No Condensation)		Grid Compliance	DIN VDE 0126-1-1; VDE-AR-N-4105; AS 4777.2; G98/G99;	
IP Class:	IP65				
Topology:	Battery Isolation				

*Subject to warranty criteria

² Firmware update may be required. Requires Firmware Version ARM V2.3.08 and DSP V2.5.76 or later

Controller Specification

Enclosure Material:	Painted Zintec Steel	Mounting Location:	Indoor
Dimensions:	146 x 165 x 51mm or 146 x 217.5 x 51mm including antenna	Supply Cable Entry:	Rear or Bottom
Supply Frequency:	50Hz	Display:	Graphical Backlit LCD
Max. Current:	0.1A	Nominal Current:	25mA
Rated Supply Voltage:	230V AC Single Phase (+/- 10%)	WiFi:	802.11b/g/n 2.4GHz
Ethernet:	1 x LAN port, RJ45 connector	Serial:	1 x RS485 port
Grid Current Sensor:	100A max. Primary Current, 16mm max, Cable Diameter	Wireless Interface:	868/915 MHz (Proprietary Protocol) for Wireless Sensor and Remote Monitoring Options
Dynamic Load Balancing:	Optional Setting to Limit Current Drawn from the Unit Supply or the Grid	Metering Accuracy:	CTs Designed to Meet Class B (1%) of EN 50470 External CTs: 0.25-100A
Compliance			
IEC62368-1, EN 55014-1&2, EN 301489-1/3/17, EN 300 220-2, EN 300 328			

Appendix A – libbi EESS Installation Schematics

Typical Arrangements

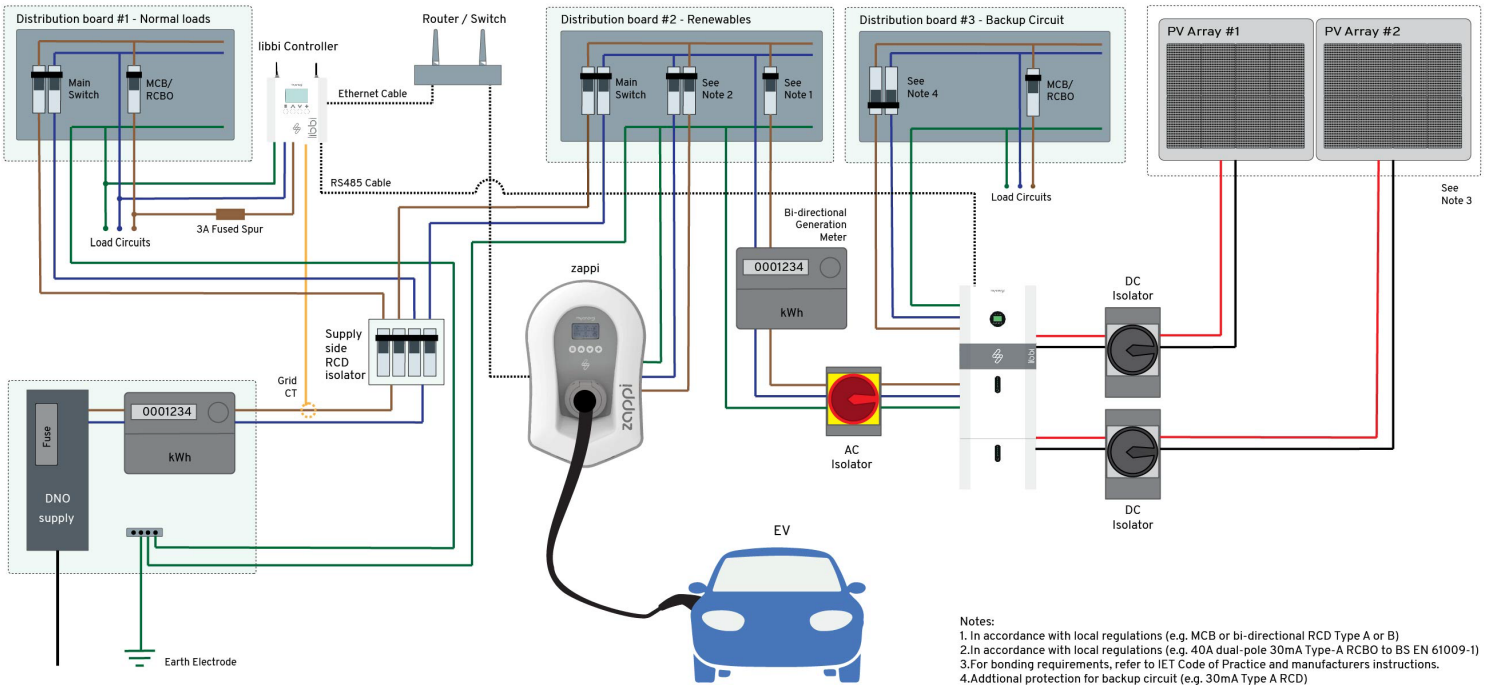

- Notes:
1. In accordance with local regulations (e.g. MCB or bi-directional RCD Type A or B)
 2. In accordance with local regulations (e.g. 40A dual-pole 30mA Type-A RCBO to BS EN 61009-1)
 3. For bonding requirements, refer to IET Code of Practice and manufacturers instructions.
 4. Additional protection for backup circuit (e.g. 30mA Type A RCD)

TT Grid Supply

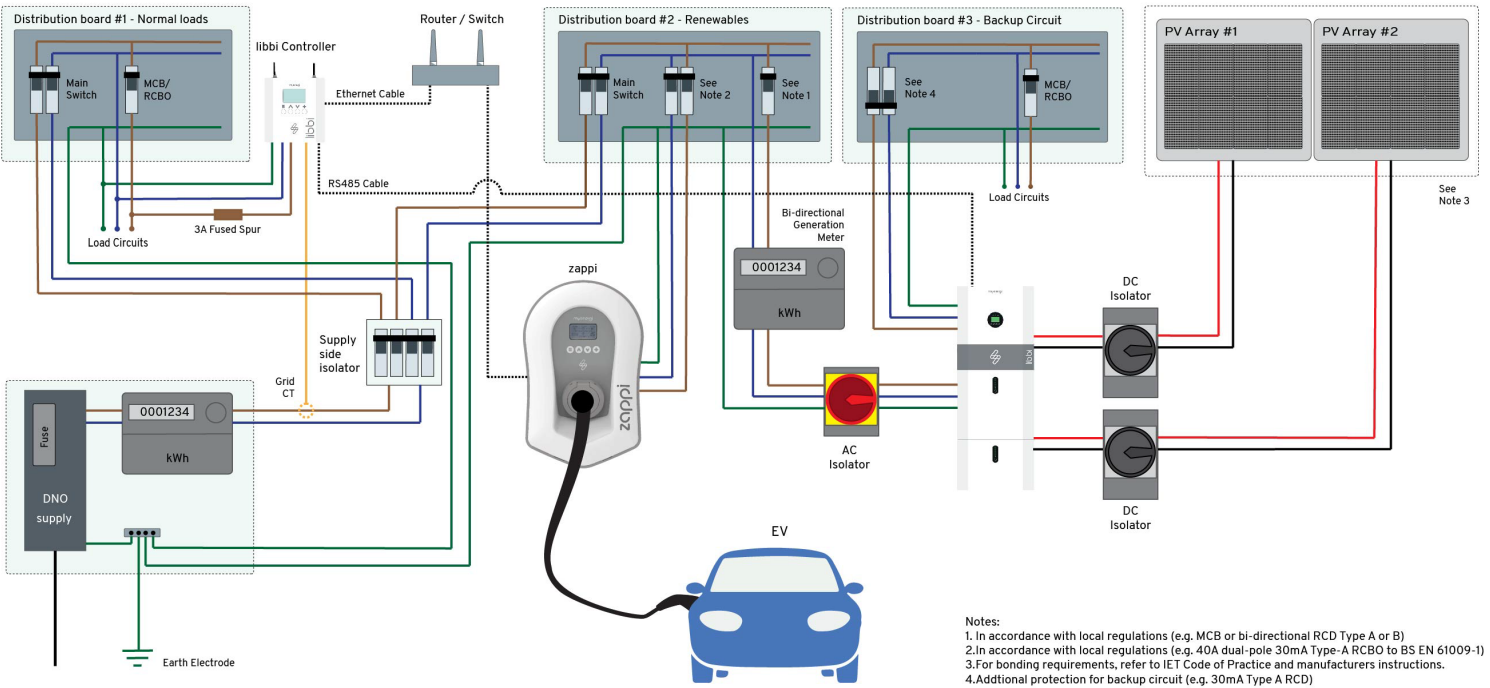

- Notes:
1. In accordance with local regulations (e.g. MCB or bi-directional RCD Type A or B)
 2. In accordance with local regulations (e.g. 40A dual-pole 30mA Type-A RCBO to BS EN 61009-1)
 3. For bonding requirements, refer to IET Code of Practice and manufacturers instructions.
 4. Additional protection for backup circuit (e.g. 30mA Type A RCD)

TN-S or TN-C-S Grid Supply

Appendix B – libbi N-E Bond Relay

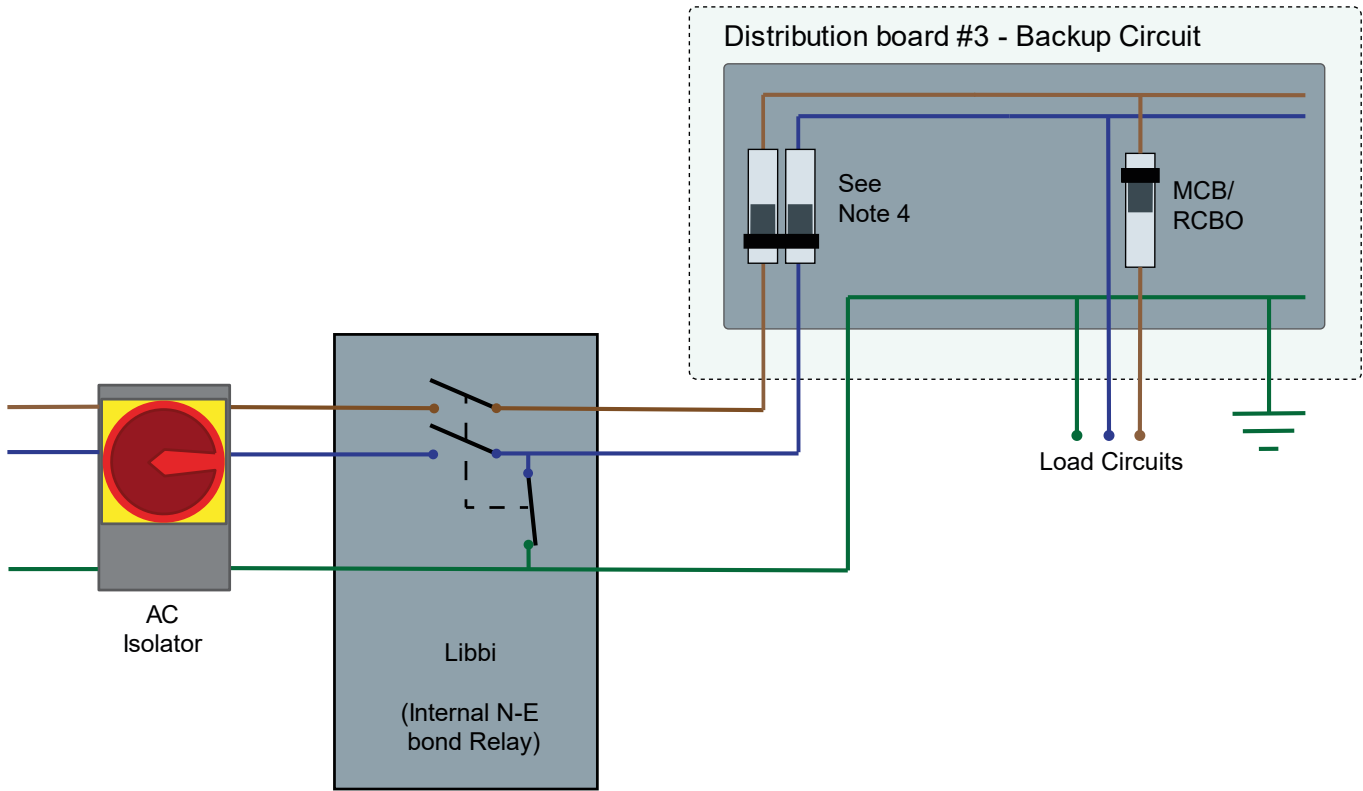

N-E Circuit for Off-Grid Conditions

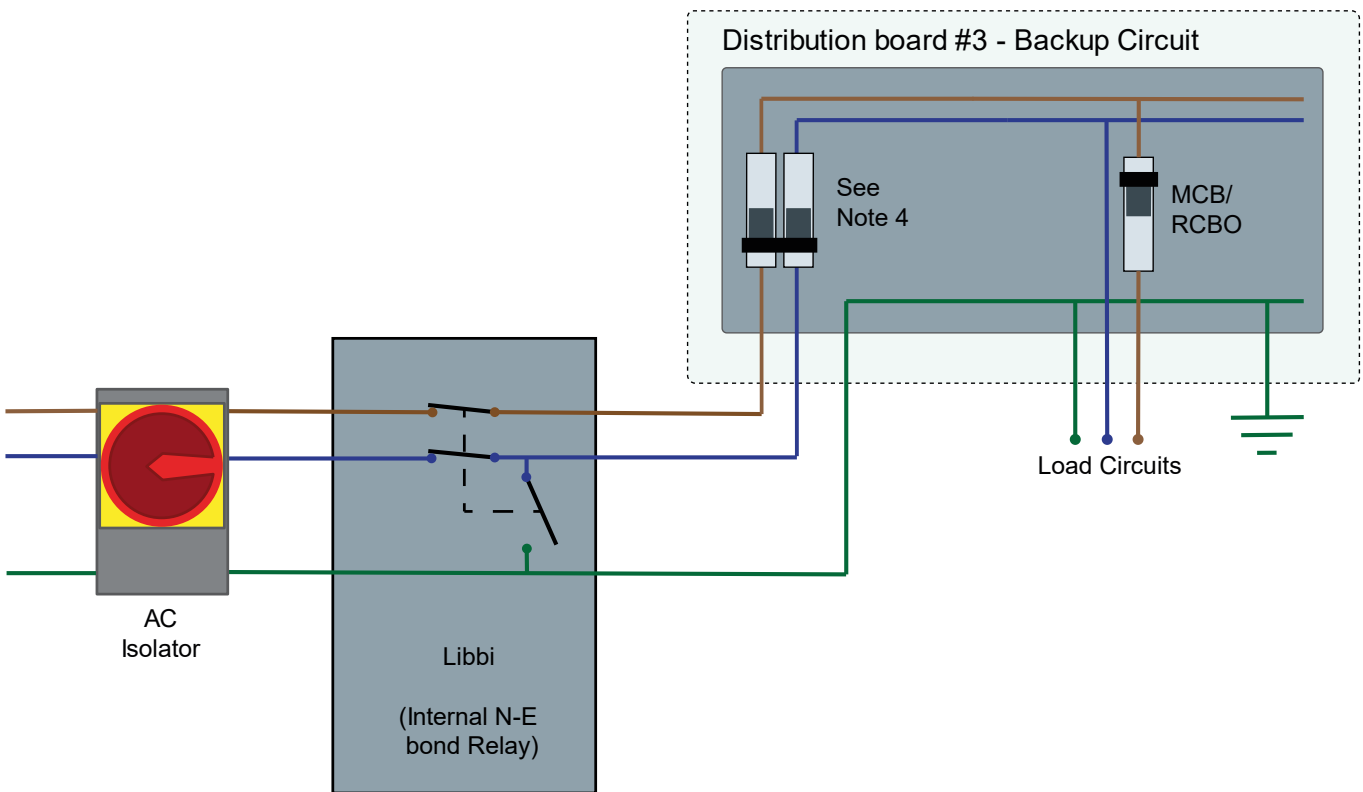

N-E Circuit for On-Grid Conditions

Appendix C – Setup Wizard Menu Map

